

BEFORE YOU BEGIN

Infiltrator Water Technologies' tanks must be installed according to state and/or local regulations and approvals, which supersede the manufacturer's installation instructions. If unsure of the installation requirements for a specific site, contact the health department or permitting authority. The IM-Series referred to in this document includes the IM-540, IM-1060, and IM-1530 models.

WARNING: IMPLOSIONS MAY CAUSE SERIOUS INJURY
 Follow Infiltrator Water Technologies vacuum test instructions

MATERIALS AND EQUIPMENT NEEDED

- | | |
|--|--|
| <input type="checkbox"/> IM-Series tank | <input type="checkbox"/> Excavator |
| <input type="checkbox"/> Access port lid(s)* | <input type="checkbox"/> Shovel |
| <input type="checkbox"/> 10 screws per lid* | <input type="checkbox"/> Level |
| <input type="checkbox"/> 2 inlet/outlet gaskets (included) | <input type="checkbox"/> 5-inch-diameter (125 mm) hole saw |
| <input type="checkbox"/> Inlet/outlet tees* | <input type="checkbox"/> Utility knife |
| <input type="checkbox"/> Tape measure | <input type="checkbox"/> PVC pipe glue with primer |
| <input type="checkbox"/> Pipe, risers, etc. | |
| <input type="checkbox"/> Socket wrench | |
- *tee and lid inclusion varies by state/province

INSTALLATION SITE SELECTION

- Do not install the tank in vehicular traffic areas. The tank is designed for non-traffic applications.
- The allowable soil cover depth is 6 to 48* inches (150 to 1,200 mm).
 *18-inch (450 mm) max. in Florida for Cat. 3 IM-Series tanks;
 48-inch (1,200 mm) max. in Florida for Cat. 4 IM-Series tanks; 36-inch (900 mm) max. in Massachusetts, New Hampshire, North Carolina, and Oregon.
- Do not install where uninterrupted saturated soil could be present from the tank bottom to a height exceeding that of the outlet pipe saddle. See page 4 illustration.

EXCAVATING AND PREPARING THE SITE

- Unless buoyancy control measures are required, the excavation width and length should be 18 to 36 inches (450 to 900 mm) larger than the tank on each side or sized as necessary to ensure proper backfill compaction, as outlined in Steps 5-10 of "Backfilling the Tank" in this document. See Infiltrator IM-Series Tank Buoyancy Control Guidance document, available online at www.infiltratorwater.com, for specific excavation requirements when installing buoyancy control measures.
- Excavation depth shall account for the 55-inch (1,375 mm) tank height. Also account for 4 inches (100 mm) of bedding (if required) and cover depth (permissible cover depth is 0.5 to 4 feet (150 to 1,200 mm) of soil).
Note: If uninterrupted saturated soil conditions exist from the tank bottom to a height exceeding that of the outlet pipe saddle, tank structural integrity may be compromised. See page 4 illustration.

Indiana installations: If the depth of the uninterrupted saturated soil conditions cannot be determined from the site soil evaluation report or other site-related data and other information indicates the possible presence of a perched ground water table, tank installation is permissible.

- Inspect bottom of excavation to verify suitability of native soil for tank installation. Soils with large, protruding, or sharp stones or other similar objects that may damage the tank are not suitable.
- The tank may be installed either in suitable native soil (see Backfilling the Tank section) or a minimum 4-inch (100 mm) layer of well-graded granular soil having particles less than 3 inches (75 mm) in diameter, or maximum 0.5-inch (13 mm) diameter crushed stone.
- Create a uniform, compacted, level surface to ensure that the bottom of the tank is evenly supported. Verify that the installation surface is flat.

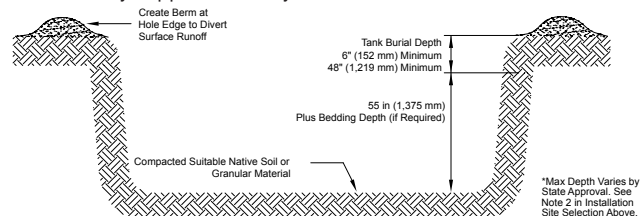

INSTALLING THE TANK

- Inspect the tank for damage before installation.
- If the tank inlet and outlet penetrations are not drilled, drill holes using the drill points provided at each of the inlet and outlet ports according to Table 3 in the Inlet and Outlet Hole Locations section. The inlet and outlet may be drilled on either the sides or ends of the tank, as required based on applicable codes and site conditions.*
 * Kentucky, Oregon, West Virginia, and certain Florida and Texas tanks are factory-drilled.
- The gaskets supplied with the tank are compatible with Schedule 40 and SDR 35 pipe using a 5-inch-diameter (125 mm) hole saw.
- Install the rubber gaskets at the inlet and outlet.
- Using all four of the tank's integral lifting lugs, lower tank into excavation.
- Slide the inlet and outlet pipes* through the gaskets. Soapy lubricant may be used to slide the pipe in.
 *For North Carolina, the inlet pipe shall be a straight pipe with no tee.
- Horizontally position the tee 1/2 inches (40 mm) from the access port rim, allowing the tee to fit into the recess in the access port lid (see detail).
- Install lids and risers (see Installing Risers section) as necessary. Rotate lid over access opening until it indexes to tank and drops into position.

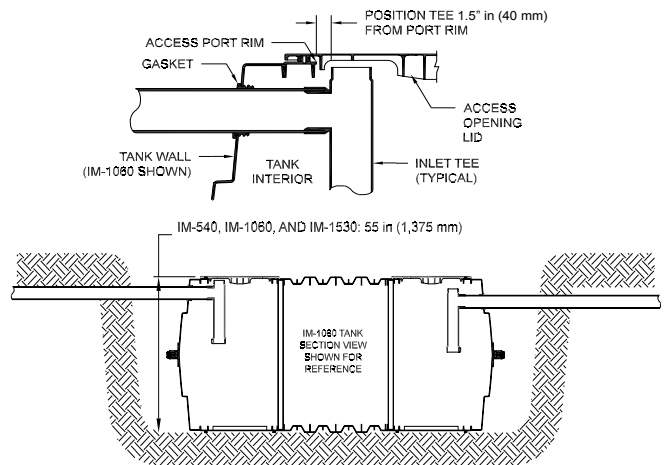

BACKFILLING THE TANK

Note: Infiltrator tanks do not require filling with water prior to backfill placement. Water filling and backfilling to the tank mid-height is required if the tank is left in either an open or backfilled excavation that may fill with water from rain or other sources.

- Backfill with suitable native soil (max. 3-inch (75-mm) stone diameter). If native soil is unsuitable, replace unsuitable fraction with suitable soil. If suitable soil is not locally available, contact Infiltrator for assistance.
- Suitable soil shall include soil textural classes defined in the United States Department of Agriculture soil triangle.
 a) For a tank soil cover depth of 0.5 to 2.0 feet (150 to 600 mm), suitable soil textures include:

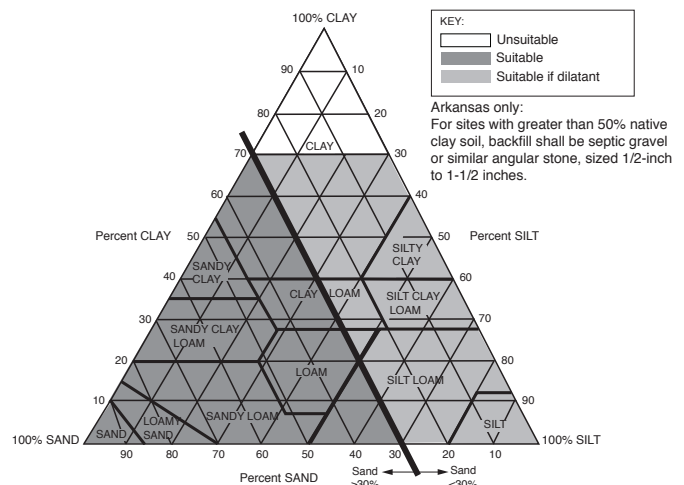

- b) For a tank soil cover depth that is greater than 2.0 feet and up to 4.0 feet (600 to 1,200 mm), suitable soil textures include:

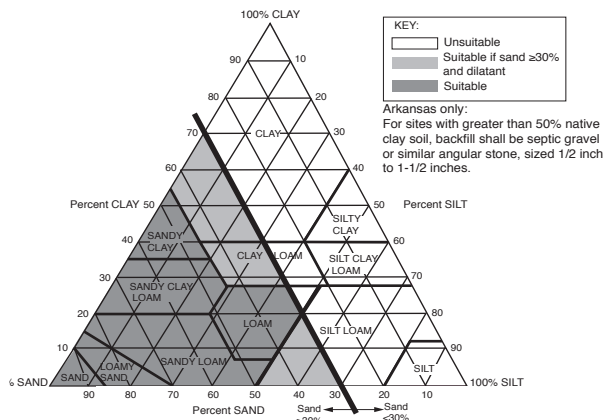

- Backfill should not have stones greater than 3 inches (75 mm) in diameter or excessive clods that do not break apart during placement and compaction. Backfill must be capable of occupying the spaces between the tank ribs and beneath the haunches.
Note: Rounded screened aggregate (e.g., pea gravel) is not a suitable backfill.
- Standard field soil classification methods shall be used to determine the soil textural class.
Note: Under most circumstances, the determination of soil dilatancy will not be required. Dilatancy shall be determined in the field using a test that does not require specialized equipment, per ASTM D2488, Section 14.3.
- Place and compact soil by walking-in beneath the haunches of the tank.
Note: Compacting soil beneath the haunches is critical for tank structural integrity.
- Place backfill around the four sidewalls in an alternating manner, so that the backfill height along the four sidewalls is maintained within a 12-inch (300-mm) tolerance.
- Do not backfill top of tank before sidewalls are completely backfilled.
- Continue to place backfill along the sidewalls in 12-inch (300-mm) lifts. Place backfill between the ribs on the sidewalls such that the space between the ribs is completely filled with soil.
- Compact backfill material either by walking-in, hand tamping or mechanical compaction (includes backhoe bucket). If mechanical compaction is used, such as a walk-behind tamper or backhoe bucket, a single pass is recommended. Compact each lift prior to placement of next lift. Compact backfill from tank walls to excavation sidewalls.
- Complete backfilling and grade the area.
- A minimum 6-inch (150-mm) depth of suitable soil must be placed over the top of the tank. The balance of backfill placed to finish grade above the tank may be either suitable or unsuitable soil.
- Establish a strong stand of erosion-resistant vegetation.
Grade to prevent the backfilled excavation from filling with surface runoff. If uninterrupted saturated soil conditions are present from the tank bottom to a height exceeding that of the outlet pipe saddle, tank structural integrity may be compromised.

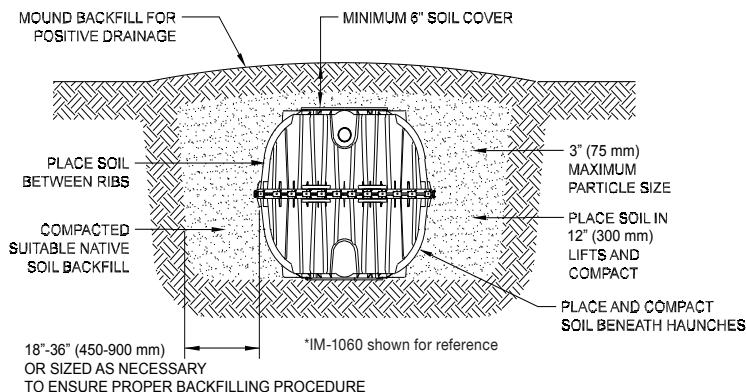

SHORT AND LONG-TERM GROUNDWATER CONTROL

It may be necessary to implement groundwater control measures during tank installation. Maintain dry conditions by expanding the excavation to create a short-

term groundwater collection sump for temporary placement of a dewatering pump if needed. Long-term groundwater control measures such as underdrains and interceptor trenches may be sensible if the site is amenable to construction of a control system and such systems are not prohibited by regulation or law, and the tank location is not subject to flooding. Properly installed underdrains and groundwater interceptor trenches may prevent the need for tank buoyancy control measures.

INSTALLING UNDER SHALLOW GROUNDWATER CONDITIONS

Buoyancy control measures may be required if the Infiltrator tank is to be installed with less than 12 inches (300 mm) of soil backfill cover, and where uninterrupted saturated soil conditions have the potential to rise 30 inches (750 mm) or more above the tank bottom. Otherwise, no buoyancy control measures are required (see Table 1). The need for buoyancy control measures must be determined based on backfill cover depth and height of uninterrupted saturated soil conditions above the tank bottom according to Table 1. Refer to Infiltrator IM-Series Tank Buoyancy Control Guidance document for more information.

Table 1: Tank models¹ and conditions requiring buoyancy control²

Position of uninterrupted saturated soil conditions above tank bottom	Soil cover depth above tank ³	
	6 in (150 mm) to 12 in (300 mm)	Above 12 in (300 mm)
Above outlet pipe saddle	Do not install tank	Do not install tank
36 in (900 mm) to outlet pipe saddle ⁴	All models	None
30 in (750 mm) to 36 in (900 mm)	IM-1530	None
Less than 30 in (750 mm)	None	None

- IM-540, IM-1060 and IM-1530.
- See Infiltrator IM-Series Tank Buoyancy Control Guidance for detailed information on the use of controls.
- No controls are required for soil cover depths exceeding 12 in (300 mm).
- The tank shall not be installed where uninterrupted saturated soil conditions could be present from the tank bottom to a height above that of the outlet pipe saddle. See page 4 illustration. For Indiana installations, if the depth of uninterrupted saturated soil conditions cannot be determined from the site soil evaluation report or other site-related data and other information indicates the possible presence of a perched ground water table, no buoyancy controls are required.

INSTALLING RISERS

- Compatible risers include 24-inch (600 mm) diameter products such as the Infiltrator EZsnap, TW-Riser, and EZset by Infiltrator, PolyLok®, Inc., and Tuf-Tite® Corporation, in addition to 24-inch (600 mm) diameter corrugated HDPE and IPEX Ultra Rib® PVC pipe. Follow Infiltrator's IM-Series Tank Riser Connection Guidance.
- In Oregon only, watertightness testing shall include filling with water at least 2 inches above riser connection, with no more than 1 gallon leakage per 24 hours, per OAR 340-073-0025(3).

INSTALLING PUMPS AND RELATED EQUIPMENT

Pumps may be supported on a stable, level 16x16-inch (400x400-mm) platform positioned on the bottom of the tank. One 16x16-inch block or two 8x16-inch (200-mm x 400-mm) side-by-side blocks may be used. Limit block height to account for pump height and liquid levels during pump cycles. Block(s) should be placed below an access opening and level upon the tank bottom. For two blocks, orient them perpendicular to ribs on the tank bottom, if present, for stability.

Installation of products such as electrical conduit and wiring, pumps, water level control equipment, valves, siphon equipment, etc. shall be in accordance with the product manufacturer's instructions and compliant with applicable state or local rules and regulations. Appurtenances shall be fastened to the tank riser system and not the tank body or access opening rim. Where possible, appurtenances shall be installed to facilitate maintenance and repair access via the tank access openings.

Note: Prefabricated pump vaults may be installed.

GENERAL SPECIFICATIONS

- Failure to comply with installation instructions will void warranty.
- Prior to ground disturbance, check for subsurface obstructions and utilities in conformance with applicable requirements.
- Operating water temperature shall be less than 100° F (40° C).
- In cold conditions, handle and backfill tank with care to prevent impact damage.
- Tanks are not fire resistant. Store away from ignition sources.
- Removal of structural bulkheads is prohibited; removal of locking clips on the IM-Series tank mid-seam connection is also prohibited.
- Only suitable for potable applications if the tank bears the NSF/ANSI 61 certification mark. Otherwise, tank is recommended for use in septic, rainwater/stormwater storage, holding, and pump applications, or other non-potable uses.
- Infiltrator tanks shall not be installed above ground. Contact Infiltrator if the 6-inch (150-mm) minimum soil cover depth cannot be met.

Table 2: Nominal Volume Chart

Liquid height above tank bottom ¹		Liquid volume in tank at indicated height (measured from tank bottom to liquid surface) ¹					
		IM-540		IM-1060		IM-1530	
		U.S. Gal	Liters	U.S. Gal	Liters	U.S. Gal	Liters
in	cm						
1	3	3	11	3	11	17	64
2	5	8	30	13	49	34	128
3	8	14	53	28	106	51	192
4	10	21	80	46	174	68	256
5	13	29	109	65	246	94	357
6	15	37	141	86	326	122	463
7	18	46	173	107	405	152	573
8	20	55	207	129	488	180	681
9	23	64	243	152	575	212	802
10	25	74	279	176	666	245	928
11	28	84	317	200	757	280	1,061
12	30	94	356	225	852	312	1,182
13	33	105	396	251	950	351	1,328
14	36	116	437	277	1,049	387	1,463
15	38	127	480	303	1,147	422	1,597
16	40	138	523	330	1,249	464	1,756
17	43	150	566	357	1,351	500	1,892
18	46	161	611	384	1,454	537	2,034
19	48	173	656	411	1,556	575	2,177
20	50	186	702	438	1,658	614	2,322
21	53	198	749	465	1,760	652	2,468
22	56	210	796	493	1,866	690	2,612
23	58	223	843	521	1,972	729	2,758
24	61	235	891	549	2,078	770	2,914
25	64	248	940	577	2,184	808	3,058
26	66	261	988	605	2,290	847	3,208
27	69	274	1,038	633	2,396	887	3,356
28	71	287	1,088	662	2,506	928	3,513
29	74	300	1,137	691	2,616	968	3,665
30	76	313	1,185	719	2,722	1,007	3,814
31	79	326	1,233	747	2,828	1,048	3,966
32	81	338	1,281	775	2,934	1,087	4,113
33	84	351	1,328	802	3,036	1,126	4,262
34	86	363	1,375	830	3,142	1,165	4,410
35	89	375	1,421	857	3,244	1,204	4,557
36	91	387	1,466	884	3,346	1,242	4,701
37	94	399	1,511	911	3,449	1,280	4,846
38	97	411	1,555	938	3,551	1,318	4,988
39	99	422	1,598	965	3,653	1,355	5,131
40	102	433	1,640	992	3,755	1,393	5,272
41	104	444	1,681	1,018	3,854	1,430	5,412
42	107	455	1,722	1,044	3,952	1,466	5,550
43	109	465	1,761	1,069	4,047	1,502	5,685
44	112	475	1,799	1,094	4,141	1,537	5,817
45	114	485	1,836	1,118	4,232	1,572	5,950
46	117	494	1,871	1,142	4,323	1,604	6,070
47	119	503	1,905	1,165	4,410	1,638	6,201
48	122	512	1,938	1,187	4,493	1,667	6,310
49	124	520	1,970	1,208	4,573	1,697	6,422
50	127	528	1,999	1,228	4,648	1,724	6,527
51	130	535	2,027	1,247	4,720	1,749	6,621
52	132	542	2,050	1,265	4,789	1,766	6,684
53	135	547	2,071	1,278	4,838	1,777	6,726
54	137	551 ³	2,087	1,287	4,872	1,785 ³	6,758

- Liquid height measured from lowermost inside surface at bottom of corrugation in tank to the liquid surface elevation.
- To determine liquid volume between liquid heights, subtract the Table 2 volume indicated for the upper and lower heights. Example: IM-1060 volume between 50 in (127 cm) and 40 in (102 cm) = 1,228 gal (4,648 L) - 992 gal (3,755 L) = 236 gal (893 L).
- The total capacity of the IM-540 tank is 552 gallons; the total capacity of the IM-1530 tank is 1,787 gallons.

INLET AND OUTLET HOLE LOCATIONS

Drill height marks are provided on all Infiltrator tank models to guide inlet and outlet hole drilling. A single drill height mark is provided at each end and side port on IM-Series tanks (example illustrated below). Holes may be drilled at the end or side inlet and outlet locations, as allowed by

state and/or local regulations. The drill height mark indicates the center point location for the hole saw. The pilot drill bit on the hole saw should be positioned at the center of the drill height mark to align the hole saw properly. Table 3 provides drilling and invert information by regulatory jurisdiction for the installation of 4-inch- (100-mm-) diameter pipe.

Table 3: Inlet and Outlet Hole Locations⁴

Jurisdiction ¹	Inlet Drill Location	Outlet Drill Location	Invert Drop (in) [mm]	Inlet Invert Height (in) [mm]		Outlet Invert Height ² and Liquid Level (in) [mm]
				Above Inside Bottom of Tank ²	Above Excavation Base ³	
IM-540 and IM-1530						
All	All	All	3.00 [76]	47.00 [1,994]	47.20 [1,199]	44.00 [1,118]
IM-1060						
All	End	End	3.00 [76]	47.00 [1,994]	47.20 [1,199]	44.00 [1,118]
	Side	Side	3.00 [76]	47.50 [1,207]	47.70 [1,212]	44.50 [1,130]
	Side	End	3.50 [89]	47.50 [1,207]	47.70 [1,212]	44.00 [1,118]
	End	Side	2.50 [64]	47.00 [1,994]	47.20 [1,199]	44.50 [1,130]

1. Kentucky, Oregon, West Virginia, and certain Florida and Texas tanks are factory drilled.
2. Invert heights are measured from the lowest interior surface at the bottom of the tank to the invert.
3. Invert heights are measured from the base of the excavation to the invert.
4. State, provincial, and local regulatory requirements supersede Table 3 information.

Limitations When Saturated Soil Conditions are Present Above Tank Bottom

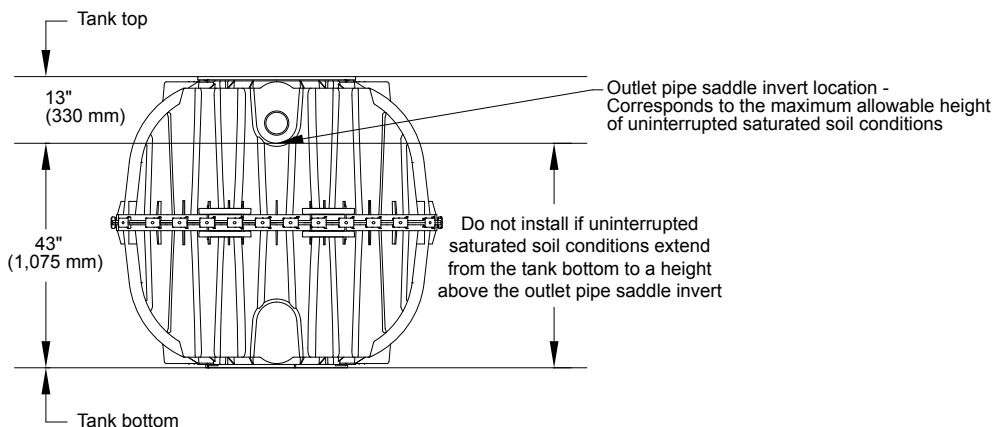

Infiltrator Water Technologies, LLC ("Infiltrator")

INFILTRATOR® SEPTIC TANK LIMITED WARRANTY FIVE (5) YEAR MATERIALS AND WORKMANSHIP LIMITED WARRANTY

- (a) This limited warranty is extended to the end user of an Infiltrator Tank. A Tank manufactured by Infiltrator, when installed and operated in accordance with Infiltrator's installation instructions and local regulation by a person or company that is properly qualified to install the Infiltrator tank in accordance with applicable state and/or local requirements, is warranted to you: (i) against defective materials and workmanship for five (5) years after installation. Infiltrator will, at its option, (i) repair the defective product or (ii) replace the defective materials. Infiltrator's liability specifically excludes the cost of removal and/or installation of the Tank.
- (b) In order to exercise its warranty rights, you must notify Infiltrator in writing at its corporate headquarters in Old Saybrook, Connecticut within fifteen (15) days of the alleged defect.
- (c) YOUR EXCLUSIVE REMEDY WITH RESPECT TO ANY AND ALL LOSSES OR DAMAGES RESULTING FROM ANY CAUSE WHATSOEVER SHALL BE SPECIFIED IN SUBPARAGRAPH (a) ABOVE. INFILTRATOR SHALL IN NO EVENT BE LIABLE FOR ANY CONSEQUENTIAL OR INCIDENTAL DAMAGES OF ANY KIND, HOWEVER OCCASIONED, WHETHER BY NEGLIGENCE OR OTHERWISE. SOME STATES DO NOT ALLOW THE EXCLUSION OR LIMITATION OF INCIDENTAL OR CONSEQUENTIAL DAMAGES, SO THIS LIMITATION OR EXCLUSION MAY NOT APPLY TO YOU. THIS WARRANTY GIVES YOU SPECIFIC LEGAL RIGHTS AND YOU MAY ALSO HAVE OTHER RIGHTS WHICH VARY FROM STATE TO STATE.
- (d) THIS LIMITED WARRANTY IS THE EXCLUSIVE WARRANTY GIVEN BY INFILTRATOR AND SUPERSEDES ANY PRIOR, CONTRARY, ADDITIONAL, OR SUBSEQUENT REPRESENTATIONS, WHETHER ORAL OR WRITTEN. INFILTRATOR DISCLAIMS AND EXCLUDES TO THE GREATEST EXTENT ALLOWED BY LAW ALL OTHER WARRANTIES, WHETHER EXPRESS OR IMPLIED, OR STATUTORY, INCLUDING ANY WARRANTY OF MERCHANTABILITY, FINESSE FOR A PARTICULAR PURPOSE AND ANY IMPLIED WARRANTIES OTHERWISE ARISING FROM COURSE OF DEALING, COURSE OF PERFORMANCE, OR USAGE OF TRADE. NO PERSON (INCLUDING ANY EMPLOYEE, AGENT, DEALER, OR REPRESENTATIVE) IS AUTHORIZED TO MAKE ANY REPRESENTATION OR WARRANTY CONCERNING THIS PRODUCT, EXCEPT TO REFER YOU TO THIS LIMITED WARRANTY. EXCEPT AS EXPRESSLY SET FORTH HEREIN, THIS WARRANTY IS NOT A WARRANTY OF FUTURE PERFORMANCE, BUT ONLY A WARRANTY TO REPAIR OR REPLACE.
- (e) YOU MAY ASSIGN THIS LIMITED WARRANTY TO A SUBSEQUENT PURCHASER OF YOUR HOME.
- (f) NO REPRESENTATIVE OF INFILTRATOR HAS THE AUTHORITY TO CHANGE THIS LIMITED WARRANTY IN ANY MANNER WHATSOEVER, OR TO EXTEND THIS LIMITED WARRANTY.
- (g) NO WARRANTY OF ANY KIND IS MADE WITH REGARD TO ANY PRODUCT, COMPONENTS, DEVICES, MEDIA OR TREATMENT UNITS WHICH ARE MANUFACTURED BY OTHERS AND ARE INSTALLED IN AN INFILTRATOR TANK. USE OF THESE PRODUCTS ARE AT YOUR OWN RISK.
- (h) THE INFILTRATOR TANK IS DESIGNED TO BE BURIED UNDERGROUND. NO WARRANTY OF ANY KIND IS MADE IF YOUR TANK IS NOT BURIED UNDERGROUND AS SPECIFIED IN THE PRODUCT'S INSTALLATION INSTRUCTIONS.

CONDITIONS AND EXCLUSIONS

There are certain conditions or applications over which Infiltrator has no control. Defects or problems as a result of such conditions or applications are not the responsibility of Infiltrator and are NOT covered under this warranty. They include failure to install the Tank in accordance with instructions or applicable regulatory requirements or guidance, altering the Tank contrary to the installation instructions and disposing of chemicals or other materials contrary to normal tank usage.

The above represents the Standard Limited Warranty offered by Infiltrator. A limited number of regulatory jurisdictions have different warranty requirements. Any purchaser of a Tank should contact Infiltrator's corporate headquarters in Old Saybrook, Connecticut, prior to such purchase to obtain a copy of the applicable warranty, and should carefully read that warranty prior to the purchase of a Tank.



4 Business Park Road
P.O. Box 768
Old Saybrook, CT 06475
860-577-7000 • Fax 860-577-7001
1-800-221-4436
www.infiltratorwater.com
info@infiltratorwater.com

Distributed By:

INFILTRATOR
water technologies

Note: Please visit www.infiltratorwater.com for updated and/or amended instructional material.

U.S. Patents: 4,759,661; 5,017,041; 5,156,488; 5,336,017; 5,401,116; 5,401,459; 5,511,903; 5,716,163; 5,588,778; 5,839,844 Canadian Patents: 1,329,959; 2,004,564 Other patents pending. Infiltrator, Equalizer, Quick4, and SideWinder are registered trademarks of Infiltrator Water Technologies. Infiltrator is a registered trademark in France. Infiltrator Water Technologies is a registered trademark in Mexico. Contour, MicroLeaching, PolyTuff, ChamberSpacer, MultiPort, PosilLock, QuickCut, QuickPlay, SnapLock and StraightLock are trademarks of Infiltrator Water Technologies. PolyLok is a trademark of PolyLok, Inc. TUF-TITE is a registered trademark of TUF-TITE, INC. Ultra-Rib is a trademark of IPEX Inc.