

July 2019

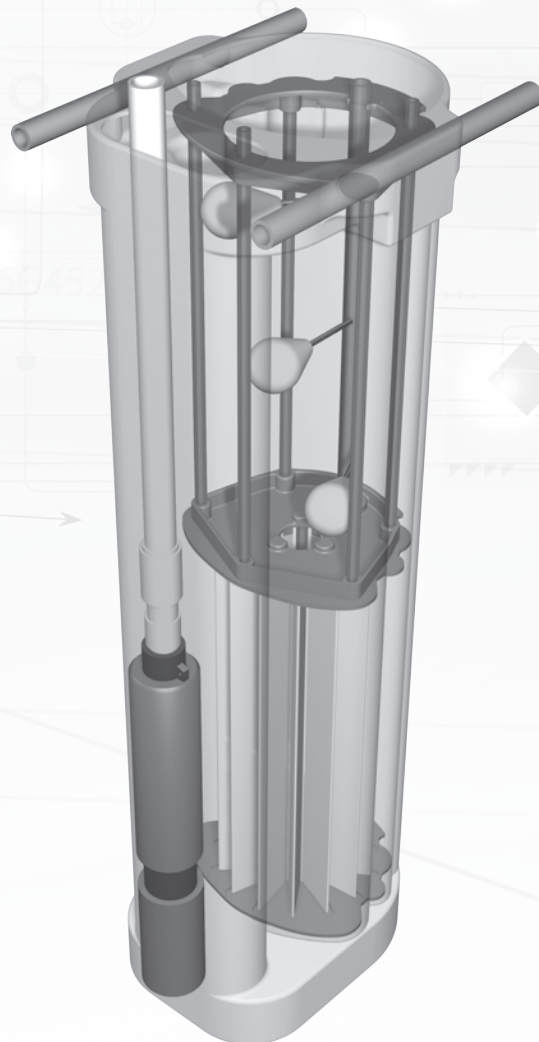

## EFFLUENT PUMPING SYSTEMS

# SAFETY INSTRUCTIONS, INSTALLATION AND SERVICE MANUAL



Delta Treatment Systems  
9125 Comar Drive  
Walker, LA 70785  
(225) 665-6162  
(800) 219-9183  
[www.deltatreatment.com](http://www.deltatreatment.com)  
[info@deltatreatment.com](mailto:info@deltatreatment.com)

# INSTALLATION INSTRUCTIONS

**THANK YOU FOR PURCHASING YOUR DELTA PUMP VAULT SYSTEM.**

**DO NOT THROW AWAY THIS MANUAL. KEEP IT IN A SAFE PLACE SO THAT YOU MAY REFER TO IT OFTEN FOR THE CONTINUED SAFE OPERATION OF THE PRODUCT.**

## **BEFORE INSTALLATION:**

This manual contains important information for the safe use of this product. Read this manual completely and follow the instructions carefully. Reasonable care and safe methods relating to the installation and operation of this product should be practiced. Check local codes and requirements before installation.

**Biohazard Risk.** Once the wastewater source has been connected to system, biohazard risk exists. Installer(s) and/or service personnel must use proper Personal Protective Equipment and follow handling procedures per OSHA 29 CFR 1910.1030 when handling equipment after wastewater source has been connected to system.

Failure to heed warnings and caution could result in injury or death.

**WARNING: BEFORE INSTALLING OR SERVICING YOUR PUMP, BE CERTAIN THE PUMP POWER SOURCE IS TURNED OFF AND DISCONNECTED. ONLY QUALIFIED PERSONNEL MAY INSTALL THIS SYSTEM. NFPA 70/ NATIONAL ELECTRIC CODE (NEC) OR LOCAL CODES MUST BE FOLLOWED. THE SYSTEM MUST BE PROPERLY GROUNDED ACCORDING TO NEC.**

**WARNING: RISK OF ELECTRICAL SHOCK – TO REDUCE RISK OF ELECTRICAL SHOCK:**

- **CONNECT ONLY TO A PROPERLY GROUNDED CONTROL PANEL.**
- **DO NOT SMOKE OR USE SPARKABLE ELECTRICAL DEVICES OR FLAME IN A SEPTIC (GASEOUS) OR POSSIBLE SEPTIC SUMP.**
- **DO NOT INSTALL PUMP IN LOCATIONS CLASSIFIED AS HAZARDOUS PER N.E.C., ANSI/NFPA 70 - 1999.**

## **ADDITIONAL WARNINGS:**

- **TANK SHOULD BE VENTED IN ACCORDANCE WITH LOCAL PLUMBING CODES**
- **A SEPTIC SUMP CONDITION MAY EXIST AND IF ENTRY INTO SUMP IS NECESSARY, THEN (1) PROVIDE PROPER SAFETY PRECAUTIONS PER OSHA REQUIREMENTS AND (2) DO NOT ENTER SUMP UNTIL THESE PRECAUTIONS ARE STRICTLY FOLLOWED.**
- **FOR USE WITH MAXIMUM 120°F WATER.**

This manual covers pump vault units of both 49” and 57” heights. Please make sure which system you are installing. The applicable size is determined by the depth of your septic tank.

## INSTALLATION INSTRUCTIONS

**Application:** The pump vault is designed for installation into either a one- or two-chamber septic or pump tank to assist in the removal of filtered effluent. Effluent is screened to filter out all solids greater than 1/8”. This screened effluent is then pumped by a high-head effluent STEP pump to the next stage of processing.

**Receiving the System:** Remove pump vault, STEP pump, and components to be sure all items are included and inspect for possible concealed damage. Any damage should be reported immediately to the delivering carrier. Claims for damage must originate with the receiver.

**Vault System Handling:** Factory built filter systems must not be dropped, dragged, rolled, or handled with sharp objects.

Improper handling of filter systems may result in damage to the basin, damage to basin components, or leaks in the piping assemblies.

**Step 1:** Determine the type of septic or pump tank you have.

**Concrete Tank:** A 19” access hole is required in a concrete tank. A 24” or 30” diameter riser with a minimum height of 18” is required for use of the pump vault. Manufacturer’s instructions must be followed for riser installation to ensure a watertight seal.

**Fiberglass / Polyethylene Tank:** These tanks typically have 24” diameter riser integral to the tank design. Refer to and follow manufacturer’s instructions if a riser of different diameter is needed (24” minimum diameter riser is required for use of the pump vault).

**Step 2** (Existing Tank use only): Empty and clean out the tank.

**Step 3:** Lower the housing only into the tank, resting the support pipes on the top of the tank.

## PUMP DISCHARGE ASSEMBLY

**Step 4:** Attach the preassembled 36” PVC pipe with pipe adapter (Figure 1, part A), pipe adapter end first, thread onto the pump. Lower the pump into the pump chamber of the housing. Note: The chamber is designed to handle either one or two STEP pumps. A single pump can be located in either side of the chamber. Place a mark on PVC pipe “A” at the height necessary to be below frost line, per local code.

**Step 5:** Position the rest of the discharge kit (Figure 1, part B) with the open end of the elbow beside the pipe marking. This determines the discharge exit location on the riser. Mark the location where the discharge pipe will exit on the riser.

Remove the pump and discharge assembly. Using a properly maintained, 2-1/2” piloted hole saw, cut a hole in the riser at the marked location. Insert the flexible grommet (provided with the discharge kit) into the drilled hole.

**Step 6:** Cut the PVC pipe (part A) at the marked location. Remove any shavings from the cut PVC pipe. Disassemble the union from part B. Use pipe cleaner to clean off the pipe and

# INSTALLATION INSTRUCTIONS

inside of the elbow from part B. Using PVC cement, attach the pipe and elbow.

**Step 7:** Cement the remaining loose joints in the discharge kit (figure 1, part B). Several joints in the discharge kit are left un-cemented at the factory to allow adjustments during installation. Verify that all joints are properly cemented and leak free before putting the filter into service.

**Step 8:** If you removed the discharge pipe from the pump to cut and assemble the kit, reattach it to the pump. Lubricate the inside lip of the discharge grommet with pipe soap. Slide the discharge pipe through the grommet. Reinstall the pump and discharge piping into the pump chamber. Align the assembly as shown in Figure 2 and assemble the union. Close the shut-off valve and attach the discharge pipe to the lateral field pipe with PVC solvent/cement. It is strongly recommended that an additional shut-off valve and redundant check valve be located outside the basin at any force main entrances - check local codes for specific requirements.

Follow STEP pump installation instructions for safe and correct pump operation.

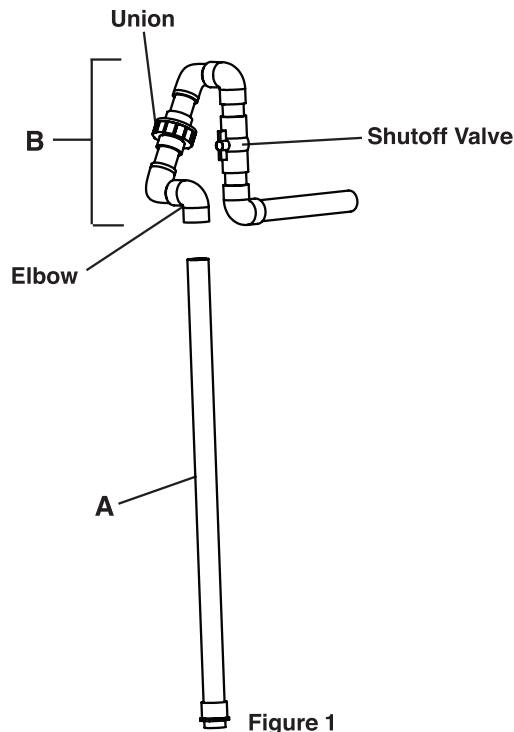

Figure 1

**WARNING: RISK OF ELECTRICAL SHOCK OR ELECTROCUTION. FAILURE TO HEED THE WARNINGS MAY RESULT IN SERIOUS INJURY, DEATH, OR FIRE HAZARD. THE INSTALLER MUST DISCONNECT ALL ELECTRICAL SOURCES PRIOR TO INSTALLATION. ONLY QUALIFIED PERSONNEL MAY INSTALL THIS SYSTEM. NFPA 70/ NATIONAL ELECTRIC CODE (NEC) OR LOCAL CODES MUST BE FOLLOWED. SYSTEM MUST BE PROPERLY GROUNDED ACCORDING TO NEC OR LOCAL CODES.**

**CAUTION: ALL LOCAL WIRING CODES MUST BE OBSERVED. CONSULT THE LOCAL INSPECTOR BEFORE INSTALLATION TO AVOID COSTLY DELAYS THAT CAN**

**OCCUR DUE TO REJECTION AFTER THE JOB IS FINISHED. ONLY QUALIFIED ELECTRICIANS SHOULD MAKE THE INSTALLATION. COMPLETE WIRING DIAGRAMS ARE INCLUDED FOR USE IN MAKING THE INSTALLATION. ALL WIRES SHOULD BE CHECKED FOR SHORTS TO GROUND WITH AN OHMMETER OR MEGGER AFTER THE CONNECTIONS ARE MADE. THIS IS IMPORTANT, AS ONE GROUNDED WIRE CAN CAUSE CONSIDERABLE TROUBLE.**

## FLOAT TREE ASSEMBLY

The float tree assembly is shipped assembled from the factory. The floats will need to be assembled to the float clips and pre-set to the 2.5" float tether length as required for proper operation. The float clips must be attached to the float tree in the proper positions in order to meet necessary reserve capacity, pump on level, pump off level, alarm level, and to meet local codes.

The floats must be staggered 20 degrees as shown in figure 3 to ensure proper operation.

The float tether length must be 2.5" as shown in figure 3 to avoid float failure.

## FILTER INSTALLATION

Lower the filter assembly into the housing until it bottoms out. Turn the PVC latch to lock the filter in place (The filter must be installed in the housing before the pump vault assembly is installed).

## JUNCTION BOX CONNECTIONS (when used)

**Step 1:** Ensure power source is off or disconnected.

**Step 2:** Install the junction box in the riser in a location which will not interfere with the removal of the filter.

**Step 3:** Install a conduit seal outside the basin to prevent surface water from entering the junction box.

**Step 4:** Push pump power and float cords through cord grips in the junction box and tighten the cord grips. To prevent corrosion or electrical short, plug any unused holes.

**Step 5:** Remove junction box cover and make all connections inside junction box to all incoming alarm/control panel wires.

## PANEL WIRING

### Electrical Connections

**Note:** Failure to use a manufacturer approved alarm or control panel voids the pump warranty and guarantee.

**IMPORTANT:** Properly connect the panel ground wire to a grounding rod. Improper grounding voids warranty.

Ensure power source is off or disconnected.

Follow the alarm/control panel installation instructions as provided by the manufacturer.

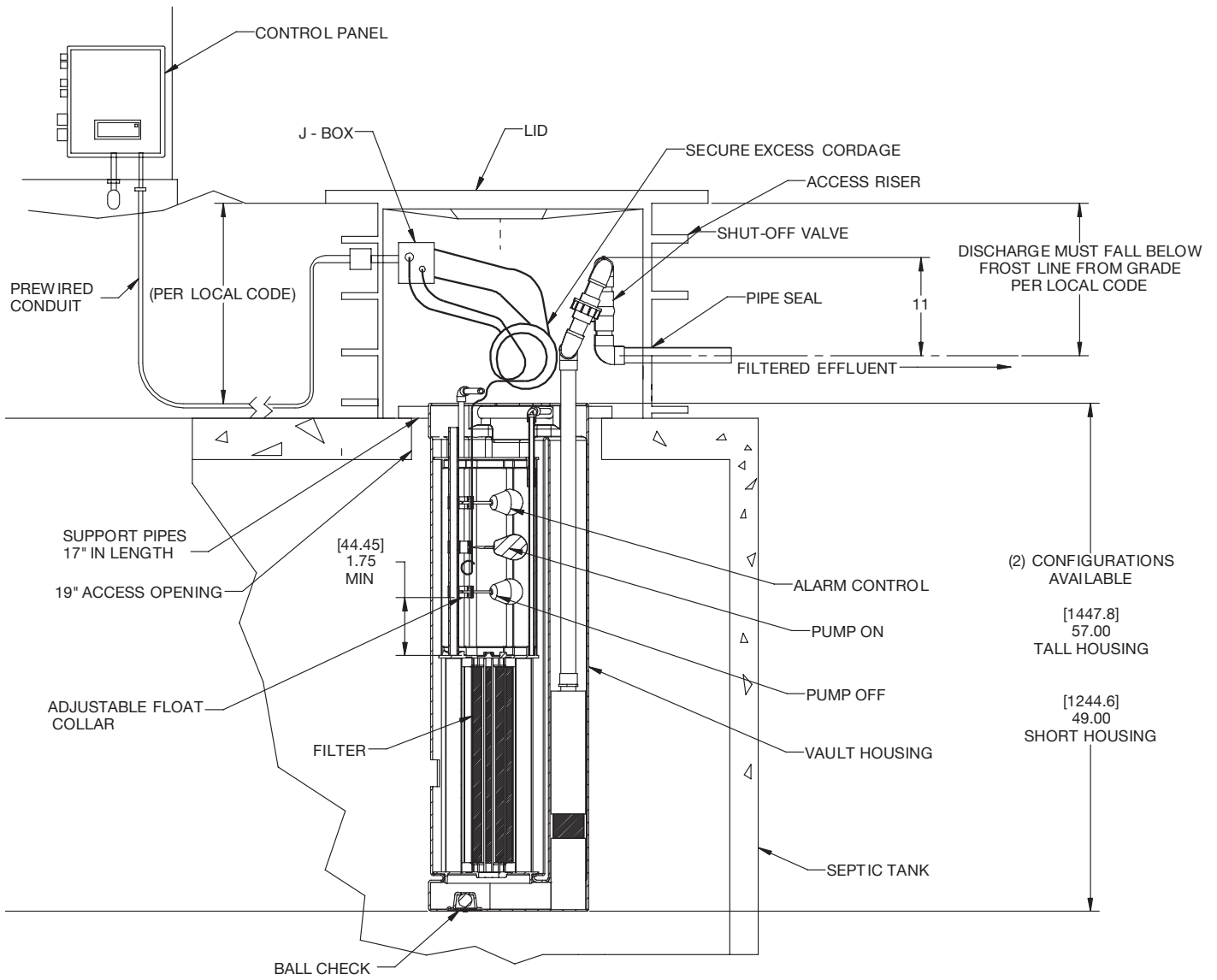
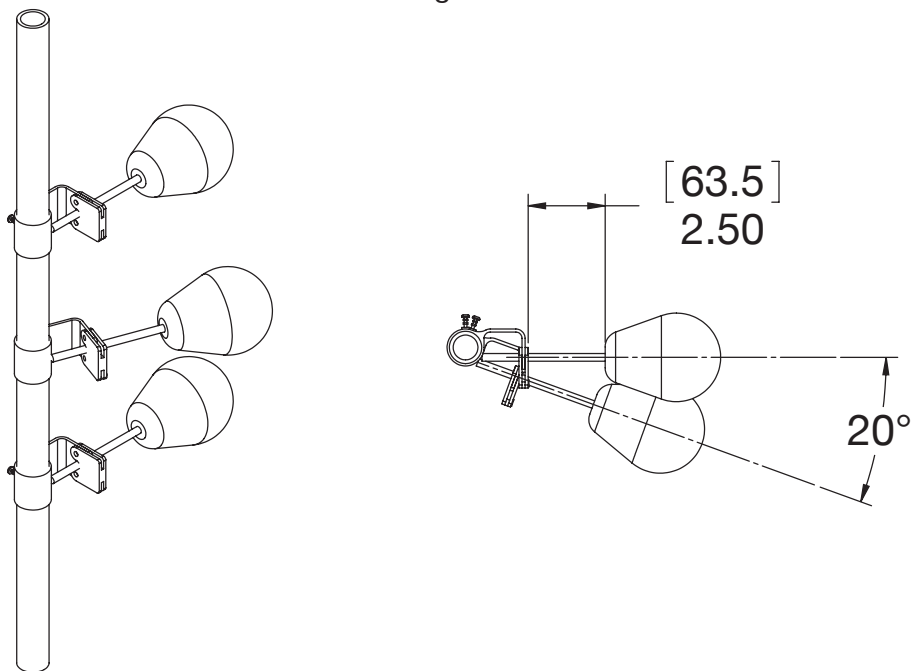

Figure 2



# START UP AND TROUBLESHOOTING

## START-UP CHECKS

Before placing the pump into operation, verify the following:

- Septic tank or pump chamber installed according to local regulations
- Septic tank or pump chamber is watertight
- Access riser and cover are installed according to manufacturer's instructions and local regulations
- Pump vault is installed according to instructions
- Float tree is installed and wired into control panel
- Float switches are free to move within vault housing
- All electrical connections are watertight and conform to the National Electric Code (NEC) and state and local regulations

**Step 1:** Run clean water into the septic tank or pump chamber.

**Step 2:** Open the shut-off valve.

**Step 3:** Turn the H-O-A switch to the Off position and turn on the main breaker.

**Step 4:** Start the pump by turning the H-O-A switch to the Hand or Manual position.

**Step 5:** Check the pump amperage with a clamp-on amp meter on the black pump lead. Readings higher than the nameplate indicate a clogged pump, miswiring, or improper voltage.

**Step 6:** Ensure H-O-A switch is set to Auto before placing system into service.

Below is a list of common problems and possible solutions. Refer to the pump and panel installation service manuals for details regarding any necessary adjusting, dismantling, or repair work.

**WARNING: RISK OF ELECTRICAL SHOCK OR ELECTROCUTION. FAILURE TO HEED THESE WARNINGS MAY RESULT IN SERIOUS INJURY OR DEATH OR FIRE HAZARD. INSTALLER MUST DISCONNECT ALL ELECTRICAL SOURCES PRIOR TO INSTALLATION. ONLY QUALIFIED PERSONNEL MAY INSTALL OR SERVICE THIS SYSTEM. NFPA 70/NATIONAL ELECTRIC CODE (NEC) OR LOCAL CODES MUST BE FOLLOWED. SYSTEM MUST BE PROPERLY GROUNDED ACCORDING TO NEC OR LOCAL CODES.**

**WARNING: BEFORE INSTALLING OR SERVICING YOUR PUMP, BE CERTAIN THAT THE PUMP POWER SOURCE IS TURNED OFF AND DISCONNECTED.**

## TROUBLESHOOTING

### *Pump won't run.*

1. Blown fuse, circuit breaker is in Off position, broken (or loose) electrical connections. Check fuses, breakers, and all electrical connections.

2. Motor overload protection contacts open. Contacts will close automatically within short time.
3. Low voltage. Check voltage at control panel.

### ***Pump runs, but no water pumped.***

1. Check valve installed backward. Reverse and reinstall.
2. The intake strainer is clogged. Remove the pump and clean the strainer.

### ***Reduced capacity.***

1. The strainer or impellers partially clogged or plugged. Remove the pump and clean the strainer. Basin level is pumped down with H-O-A in Hand or Manual position, but will not pump down in Automatic.
2. Floats are not hanging free in the basin or are covered with grease. Pump the level down with the H-O-A switch in Hand or Manual, so that the floats can be observed. Relocate and clean float(s) as necessary.
3. If this is a new installation and original start-up, the floats may be miswired in the control/alarm panel. If the On and Off floats are reversed, the pump will short-cycle On and Off and will not pump the level down.
4. Floats are malfunctioning. Pull the floats out of the basin and hang the Off and On floats from your hand. Turn the H-O-A switch to Auto. Tilt the Off float so that the large end is above the cord end (nothing should happen). While keeping the Off float tilted, tilt the On float in the same manner (the pump should come on). Suspend the On float again from your hand (the pump should continue to run). Finally, suspend the Off float from your hand (the pump should stop running). If this procedure does not cause the pump to operate as described, replace the float(s).

**BIOHAZARD RISK. ONCE THE WASTEWATER SOURCE HAS BEEN CONNECTED TO SYSTEM, BIOHAZARD RISK EXISTS. INSTALLER(S) AND/OR SERVICE PERSONNEL MUST USE PROPER PERSONAL PROTECTIVE EQUIPMENT AND FOLLOW HANDLING PROCEDURES PER OSHA 29 CFR 1910.1030 WHEN HANDLING EQUIPMENT AFTER WASTEWATER SOURCE HAS BEEN CONNECTED TO SYSTEM.**

**RISK OF FIRE OR EXPLOSION. DO NOT SMOKE OR USE OPEN FLAMES IN OR AROUND THIS SYSTEM. THIS SYSTEM IS NOT INTENDED FOR USE IN HAZARDOUS LOCATIONS PER NFPA 70 NATIONAL ELECTRIC CODE. CONSULT FACTORY FOR OPTIONAL EQUIPMENT RATED FOR THIS USE.**

**WARNING: BEFORE INSTALLING OR SERVICING YOUR PUMP, BE CERTAIN THAT THE PUMP POWER SOURCE IS TURNED OFF AND DISCONNECTED.**

The pump vault system requires periodic maintenance to ensure proper operation.

# START UP AND TROUBLESHOOTING

## SERVICE FREQUENCY

The pump vault system prevents solids larger than 1/8" from entering drain lines. As a result, solids will periodically build up between the housing and filter. This requires the filter to be cleaned off. The service interval will depend upon usage patterns.

At a minimum, the pump vault housing and filter should be cleaned each time the septic or pump tank is pumped out. Annual inspections by certified service personnel are recommended.

Any high water alarm is an indication that attention to the system is required. Frequent high water alarm activation is an indication that system service is required.

## SERVICING THE SYSTEM

The following tasks should be performed each time the pump vault system is serviced:

- Step 1:** Turn off power to the system.
- Step 2:** Check the sludge level of the septic tank. If the sludge level reaches the bottom of the pump vault housing inlet, the septic tank must be pumped out.
- Step 3:** Remove the pump, clean off the pump screen, and inspect the pump for any damaged or malfunctioning components. Repair or replace components as necessary.
- Step 4:** Remove the filter and remove any debris. Inspect the filter for damage. Replace the filter if there are any tears or breaks.
- Step 5:** Remove any debris from the vault housing and inspect the housing for damage.
- Step 6:** Reassemble the housing, filter and pump and reinstall in the tank.
- Step 7:** Turn system power back on.
- Step 8:** Test float and alarm/control panel operation and repair/ replace any malfunctioning components.

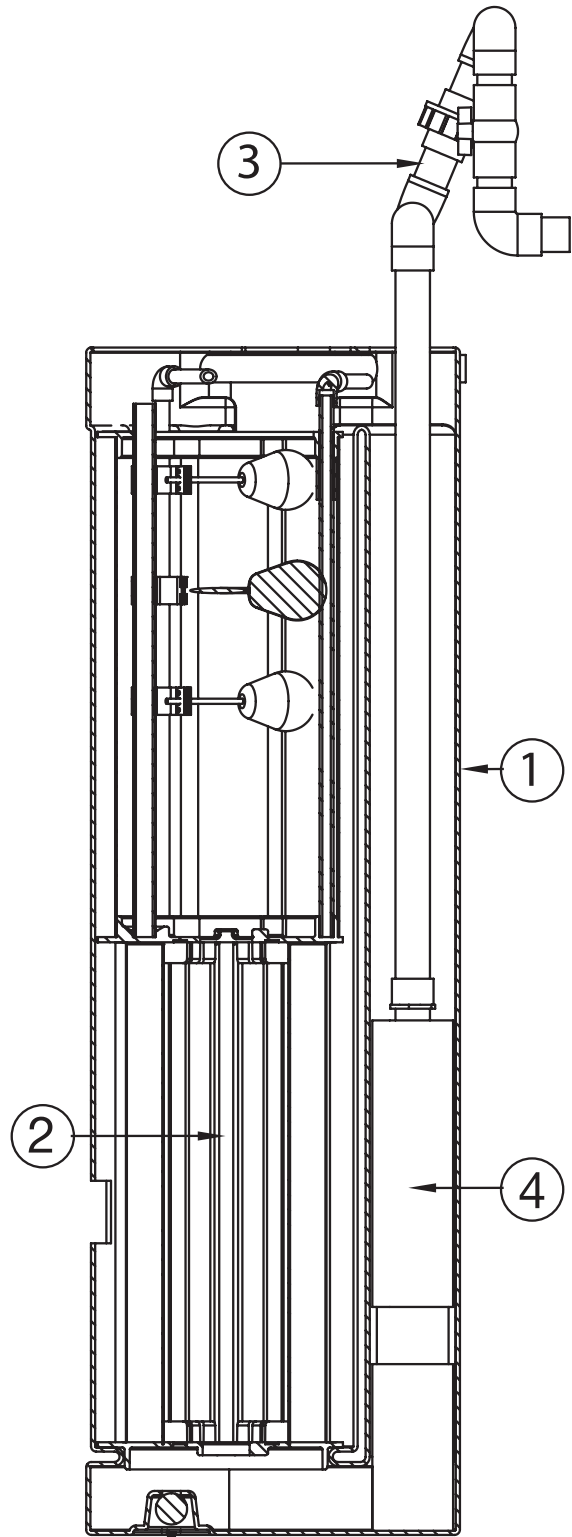

No.	Description	49"	57"
1	Housing	77-1580-1-GREEN	77-1581-1-GREEN
2	Filter Assembly	27624D001	27624D002
3	Discharge Kit*	SDA125	SDA125***
4	Effluent Pump**	WE20	WE20

\*Discharge kit includes union, ball valve, pipe, and pump/pipe adapter.

\*\* Consult factory for available pump sizes.

\*\*\* Available in Duplex configuration, consult factory for details.



# Delta Treatment Systems

## Homeowner's Manual: Onsite Wastewater Treatment System

### A Guide to the Proper Care and Maintenance of Your Onsite Wastewater Treatment System

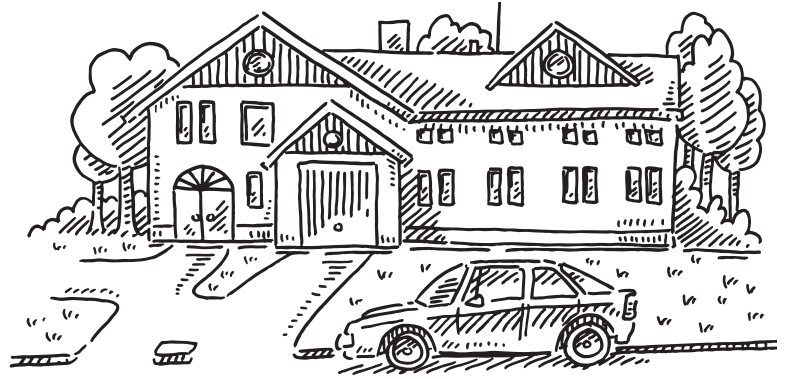

### How to Take Care of Your Wastewater Treatment System

Congratulations, your home is now serviced by a meticulously engineered wastewater treatment system. Your new Delta wastewater treatment system is designed for the collection and treatment of your household wastewater.

When properly maintained, onsite wastewater treatment systems efficiently treat household wastewater and recycle local groundwater. Delta wastewater treatment systems use little energy and can often outperform municipal sewage treatment plants. The treated wastewater, or effluent, is often returned to the soil where it will receive a final level of treatment before it reenters and recharges the groundwater. With an onsite wastewater treatment system there's no degrading of our nation's rivers and oceans, which is often the case with municipal sewer system outflows.

Your Delta wastewater treatment system is like any other engineered system, like your heat pump or

your car. Engineered systems will last longer and offer optimal performance if maintained regularly by a qualified service provider. In the case of your Delta wastewater treatment system, the service provider will likely be the person who installed the system as they're the most familiar with the ins and outs of the system and where all of the components are located on your property.

Aside from regularly scheduled maintenance of the system, it's also important to be cautious of what you put into the system. The following pages outline some of the do's and don'ts to keep in mind to ensure the longevity of your Delta wastewater treatment system.

By following a maintenance schedule and our best practice recommendations in the do's and don'ts section, your Delta wastewater treatment system should function for decades. You'll also save water, energy, and pumpout costs, too!



**Don't flush dangerous or damaging substances into your system.**

# Wastewater Treatment System Inside the Home



## DO's



Collect any cooking grease or leftover oils in a container and dispose of them in your trash can. Compost food scraps or dispose of them into the trash can. Food byproducts can accelerate the need for pumping of your tank and increase overall maintenance cost.

Keep lint out of your wastewater treatment system by cleaning the lint filters on your washing machine and dryer before every load. Installing a supplemental lint filter on your washing machine would be a good precautionary measure.

Try to use substitutes for common hazardous waste that can be found in many cleaners. Replace the following with products that are less harmful to the environment.

- **Ammonia-Based Cleaners for Baking Soda/Vinegar:** For surfaces, sprinkle baking soda on a damp sponge. For windows, use a solution of 2 tbs (30 mL) white vinegar to 1qt (1 L) water and pour the mixture into a spray bottle.
- **Carpet/Upholstery Cleaners for Cornstarch/Baking Soda:** Sprinkle dry cornstarch or baking soda on the surface and then vacuum.
- **Disinfectants for Borax:** Use ¼ cup (50 g) of Borax in a half-gallon (2 L) of water and store in a spray bottle. This solution will also work as a deodorizer.
- **Drain Decloggers:** Use a plunger or snake to remove and clean the drain trap.
- **Scouring Cleaners & Powders for Baking Soda/BonAmi® cleanser:** Sprinkle baking soda on a damp sponge or add 4 tbs (50g) baking soda to 1 qt (1 L) warm water. Or use BonAmi® cleanser; it's less expensive and is less likely to scratch the surface.
- **Furniture/Floor Polishes for Oil Soap/Lemon Juice:** Use oil soap and warm water, and dry with a soft cloth. To polish, use 1 part lemon juice and 2 parts oil (any kind) or use natural products with lemon oil or beeswax in mineral oil.
- **Laundry Detergents:** Choose a liquid detergent without chlorine or phosphates. Avoid using powdered detergents.
- **Metal Cleaners for Toothpaste/Lemon:** To polish

silver gently rub with toothpaste and soft wet cloth. To clean and polish brass and copper, scrub with half of a lemon dipped in salt. To clean stainless steel, use a scouring pad and soapy water.

- **Oven Cleaners for Baking Soda/BonAmi® cleanser:** Sprinkle the surface with baking soda or Bon Ami® then scrub with an unused toilet brush.

Practice water conservation with these tips. Using excessive amounts of water can cause hydraulic overload of the system. On average, 50 gallons (200 liters) per person per day is typical. Below are some water conservation tips to consider to ensure you're not overloading the system.

- Take shorter showers or baths with a partially filled tub. Be cautious about excessive use of large soaking tubs.
- Don't let water run unnecessarily while brushing teeth or washing hands, food, dishes, etc.
- Don't use the dishwasher or washing machine unless you have a full load. And, when possible avoid doing several loads in one day.
- Install water-saving devices on faucets and showerheads.
- When you need to replace an old toilet, replace it with a low-flush model.



# Wastewater Treatment System Inside the Home



## DON'T'S



Don't flush dangerous or damaging substances into your system.

- Pharmaceuticals
- Excessive Amounts of Bath or Body Oils
- Water Softener Backwash
- Flammable or Toxic Products
- Household Cleaners
- Chlorine Bleach, Chlorides, and Pool/Spa Products
- Pesticides, Herbicides, Agricultural Chemicals, or Fertilizers
- Eggshells, Cantaloupe Seeds, Gum, Coffee Grounds, or Tea Bags
- Chewing Tobacco or Cigarette Butts
- Condoms, Dental Floss, Sanitary Napkins or Tampons, Diapers
- Paper Towels, Newspapers, Candy Wrappers
- Large Amounts of Hair
- Baby, Medicated, or Cleaning Wipes (even those that claim to be "flushable" on the packaging)

**Don't plumb water softener discharge brine into your wastewater system** (softened water is ok, just not the brine that is produced during the regeneration cycle). Route the brine around your wastewater system so it discharges directly into the soil.

**Don't use special additives that are marketed to enhance the performance of your system.** Additives can cause damage in other areas of the collection system by disrupting the natural microorganisms that are currently growing within the system.

**Don't leave interior faucets on to protect water lines during cold weather.** A single running faucet can easily increase your daily flow up to 3,000 gallons per day and hydraulically overload your system. Properly insulate or heat your faucets and plumbing in preparation for winter months.

**Don't ignore leaky plumbing fixtures.** A leaky toilet can waste up to 2,000 gallons (7,500 liters) of water per single day, 10-20 times more water than an average household's daily use. Leaky plumbing fixtures increases your water bill, wastes natural resources and causes unnecessary overload on your system.

---

## Wastewater Treatment System Do's and Don'ts: Outside the Home

### Do's:

- Keep the tank's access lid secure at all times. Never open or attempt to enter the tank. Gasses present within the tank can be fatal. If you find the lid has become loose contact your service providerservice provider or Delta Treatment Systems.
- Plan landscaping and permanent outdoor structures before installation of the system.

### Don'ts:

- Never drive over any buried components of the system. If your system is in an area that could potentially be subject to any vehicular traffic place a barricade like a row of shrubs around it.

- Don't dump waste from your RV. This will not only cause an increase to the frequency of septage pumping but, when dumped directly into the pumping vault, RV waste clogs or fouls equipment causing unnecessary maintenance and repair costs. Additionally, some RV waste may contain chemicals that are toxic or may have a negative impact to the biological digestion occurring within the tank.
- Don't connect rain gutters or storm drains to the system or allow any surface water to enter it.
- Don't discharge hot tub water into your system.
- Don't dig without knowing the location of your wastewater system components.

## SET-UP AND MAINTENANCE NOTES

---

---

---

---

---

---

---

---

---

---

---

---

---

---

---

---

---

---

---

---

---

---

---

---

---

# WARRANTY

---

## **DELTA TREATMENT SYSTEMS, LLC (“DELTA”) DELTA TREATMENT SYSTEMS, LLC STANDARD LIMITED WARRANTY (NON-NSF PRODUCTS)**

- (a) Each component manufactured by Delta (“Unit”) when installed and operated in accordance with Delta’s instructions, is warranted to the original purchaser (“Holder”) against defective materials and workmanship for one (1) year from purchase. To exercise its warranty rights, Holder must notify Delta in writing at its Corporate Headquarters in Walker, Louisiana within fifteen (15) days of the alleged defect. Delta reserves the right to inspect the Unit to confirm that it is defective. Delta will supply a replacement Unit for a Unit determined by Delta to be covered by this Limited Warranty. Delta’s liability specifically excludes the cost of removal and/or installation of the Unit.
- (b) YOUR EXCLUSIVE REMEDY WITH RESPECT TO ANY AND ALL LOSSES OR DAMAGES RESULTING FROM ANY CAUSE WHATSOEVER SHALL BE SPECIFIED IN SUBPARAGRAPH (a) ABOVE. DELTA SHALL IN NO EVENT BE LIABLE FOR ANY CONSEQUENTIAL OR INCIDENTAL DAMAGES OF ANY KIND, HOWEVER OCCASIONED, WHETHER BY NEGLIGENCE OR OTHERWISE. SOME STATES DO NOT ALLOW THE EXCLUSION OR LIMITATION OF INCIDENTAL OR CONSEQUENTIAL DAMAGES, SO THIS LIMITATION OR EXCLUSION MAY NOT APPLY TO YOU. THIS WARRANTY GIVES YOU SPECIFIC LEGAL RIGHTS AND YOU MAY ALSO HAVE OTHER RIGHTS WHICH VARY FROM STATE TO STATE.
- (c) THIS LIMITED WARRANTY IS THE EXCLUSIVE WARRANTY GIVEN BY DELTA AND SUPERSEDES ANY PRIOR, CONTRARY, ADDITIONAL, OR SUBSEQUENT REPRESENTATIONS, WHETHER ORAL OR WRITTEN. DELTA DISCLAIMS AND EXCLUDES TO THE GREATEST EXTENT ALLOWED BY LAW ALL OTHER WARRANTIES, WHETHER EXPRESS OR IMPLIED, OR STATUTORY, INCLUDING ANY WARRANTY OF MERCHANTABILITY, FINESSE FOR A PARTICULAR PURPOSE AND ANY IMPLIED WARRANTIES OTHERWISE ARISING FROM COURSE OF DEALING, COURSE OF PERFORMANCE, OR USAGE OF TRADE. NO PERSON (INCLUDING ANY EMPLOYEE, AGENT, DEALER, OR REPRESENTATIVE) IS AUTHORIZED TO MAKE ANY REPRESENTATION OR WARRANTY CONCERNING THIS PRODUCT, EXCEPT TO REFER YOU TO THIS LIMITED WARRANTY. EXCEPT AS EXPRESSLY SET FORTH HEREIN, THIS WARRANTY IS NOT A WARRANTY OF FUTURE PERFORMANCE, BUT ONLY A WARRANTY TO REPAIR OR REPLACE DEFECTIVE COMPONENTS.
- (d) Delta shall not be liable for penalties or liquidated damages, including loss of production and profits, labor and materials, overhead costs, or other losses or expenses incurred by the Holder or any third party. Specifically excluded from Limited Warranty coverage are damage to the Units due to ordinary wear and tear, alteration, accident, misuse, abuse or neglect of the Units; the Units being subjected to conditions which are not permitted by the installation instructions. In no event shall Delta be responsible for piping or plumbing necessary to replace the defective Unit. This Limited Warranty shall be void if the Holder fails to comply with all of the terms set forth in this Limited Warranty. Further, in no event shall Delta be responsible for any loss or damage to the Holder, the Units, or any third party resulting from installation or shipment, or from any product liability claims of Holder or any third party. For this Limited Warranty to apply, the Units must be installed in accordance with all site conditions required by state and local codes; all other applicable laws; and Delta’s installation instructions.
- (e) You may assign this Limited Warranty to a subsequent purchaser of you home. No other assignments are permitted. The above represents the Standard Limited Warranty offered by Delta. A limited number of states and counties have different warranty requirements. In addition, certain NSF certified Ecopod and Whitewater devices and components manufactured by Delta have a different warranty. Any purchaser of Units should contact Delta’s Corporate Headquarters in Walker, Louisiana, prior to such purchase, to obtain a copy of the applicable warranty, and should carefully read that warranty prior to the purchase of Units.



DELTA TREATMENT SYSTEMS, LLC  
9125 Comar Drive, Walker, LA 70785  
(225) 665-6162 • (800) 219-9183  
[www.deltatreatment.com](http://www.deltatreatment.com)  
[info@deltatreatment.com](mailto:info@deltatreatment.com)