



The Infiltrator IM-Series Potable water tanks are lightweight, strong and durable. These potable, watertight tank designs are offered with Infiltrator's potable heavy-duty lids. Infiltrator injection-molded tanks provide a revolutionary improvement in plastic tank design, offering long-term exceptional strength and watertightness. Infiltrator's IM-Series Potable water tanks are available in 552-gallon, 1287-gallon and 1787-gallon capacities.

Features & Benefits

- Strong injection-molded polypropylene construction
- NSF/ANSI-61-certified for potable uses
- Lightweight plastic construction and inboard lifting lugs allow for easy delivery and handling
- Integral heavy-duty green lids that interconnect with EZsnap risers and pipe riser solutions
- Structurally reinforced access ports eliminate distortion during installation and pump-outs
- Reinforced structural ribbing and fiberglass bulkheads offer additional strength
- Can be installed with 6" to 48" of cover
- Can be pumped dry
- Suitable for use as a potable pump tank, rainwater harvesting tank or water storage tank
- No special water filling requirements are necessary
- The tank may be backfilled with suitable native soil. See installation instructions for guidance.
- Available in 552-gallon, 1287-gallon and 1787-gallon capacities

TANK CUTAWAY

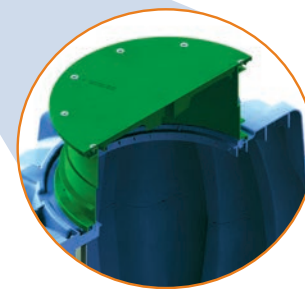
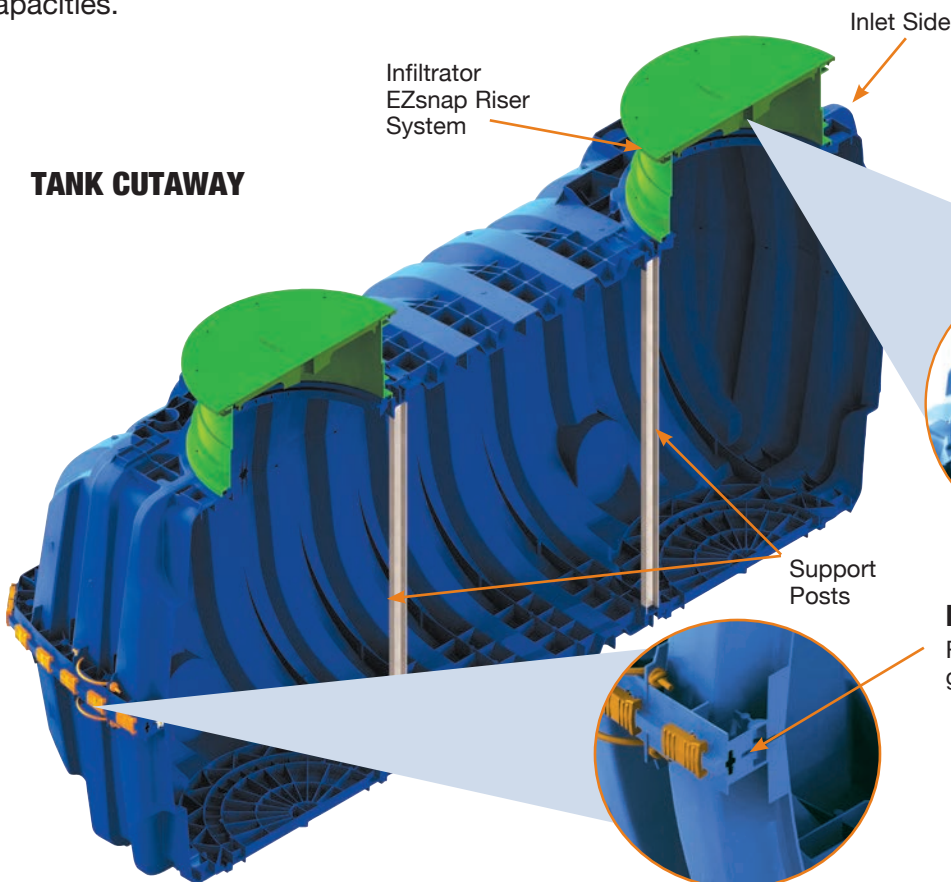

HEAVY DUTY LID CUTAWAY

Reinforced 24" structural access port

MID-SEAM CUTAWAY

Reinforced water tight mid-seam gasketed connection



IM-Series Potable Water Tanks

General Specifications and Illustrations

The IM-Series Potable water tanks are injection-molded, two piece, mid-seam plastic tanks. The injection-molded plastic design allows for a mid-seam joint that has precise dimensions for accepting an engineered EPDM gasket. Infiltrator's gasket design utilizes technology from the water industry to deliver proven means of maintaining a watertight seal. The two-piece design is permanently fastened using a series of non-corrosive plastic alignment dowels and locking seam clips. The IM-Series Potable water tanks are assembled and sold through a network of certified Infiltrator distributors and are NSF/ASNI-61-certified for potable uses.

Must be backfilled and installed in accordance with Infiltrator Water Technologies, Infiltrator IM-Series Septic Tank General Installation Instructions and for shallow ground water conditions reference the Infiltrator IM-Series Tank Buoyancy Control Guidance.

Please visit www.infiltratorwater.com for the latest information.

IM-Potable Water Tank Series			
Parameter	IM-550C	IM-1280C	IM-1760C
Total Capacity	552 gal (2089 L)	1287 gal (4872 L)	1787 gal (6765 L)
Length (A)	65 (1651 mm)	127" (3226 mm)	176" (4460 mm)
Width (B)	62 (1575 mm)	62 (1575 mm)	62 (1575 mm)
Height (C)	55 (1397 mm)	55 (1397 mm)	55 (1397 mm)
Fiberglass Supports	0	2	4
Maximum Burial Depth	48" (1219 mm)	48" (1219 mm)	48" (1219 mm)
Minimum Burial Depth	6" (152 mm)	6" (152 mm)	6" (152 mm)
Maximum Pipe Diameter	4" (100 mm)	6" (152 mm)	4" (100 mm)
Weight	191 (87 kg)	346 (157 kg)	501 (227 kg)

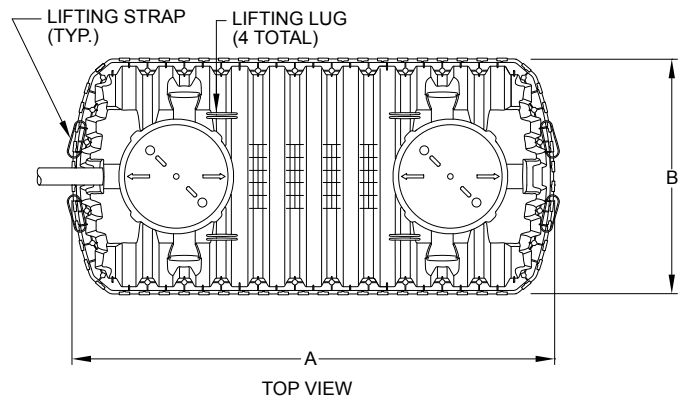

TOP VIEW

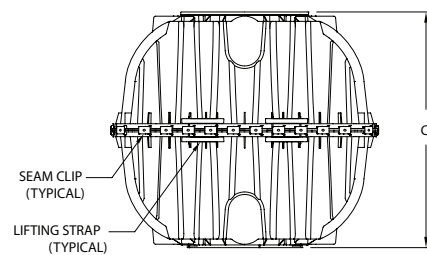

END VIEW

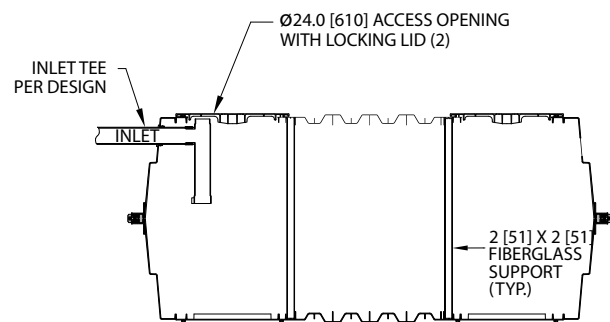

SIDE VIEW

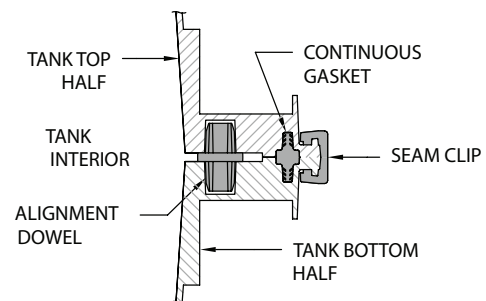

MID-HEIGHT SEAM SECTION



4 Business Park Road
P.O. Box 768
Old Saybrook, CT 06475
860-577-7000 • Fax 860-577-7001
1-800-221-4436
www.infiltratorwater.com
info@infiltratorwater.com

U.S. Patents: 8322948; 8337119; 8297880; 7914230; 7008138. Other patents pending. Infiltrator, Quick4 and EZflow are registered trademarks of Infiltrator Water Technologies. Infiltrator Water Technologies is a wholly-owned subsidiary of Advanced Drainage Systems, Inc. (ADS).

© 2023 Infiltrator Water Technologies, LLC. Not responsible for any typographic errors. Printed in U.S.A.

IM23 0623

Contact Infiltrator's Technical Services Department for assistance at 1-800-221-4436