

November 2020

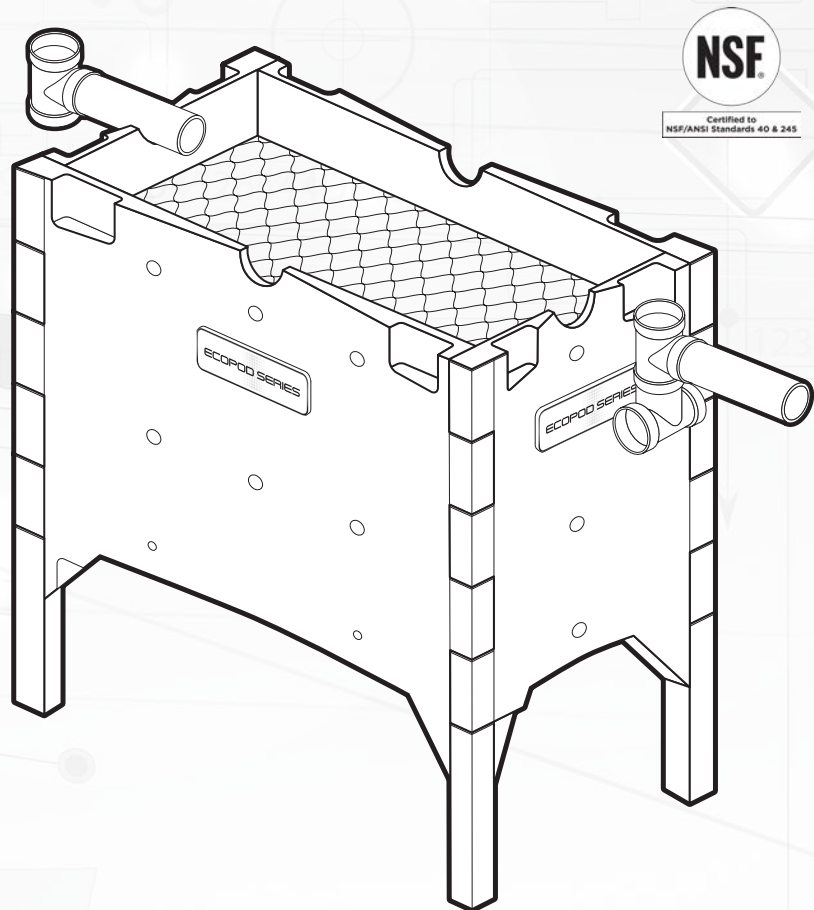

FIXED FILM WASTEWATER TREATMENT SYSTEM

INSTALLATION, OPERATION AND MAINTENANCE MANUAL



Delta Treatment Systems
9125 Comar Drive
Walker, LA 70785
(225) 665-6162
(800) 219-9183
www.deltatreatment.com
info@deltatreatment.com

TABLE OF CONTENTS

Distributor and Homeowner Notes	2
ECOPOD-N® Treatment Systems Notice	3
Introduction.....	4
Installation Instructions.....	8
Troubleshooting Guide.....	10
ECOPOD-N Unit Specifications	12
Data Plates	21
Service Policy.....	22
Homeowners Manual	23
Warranty	26

NOTE: To the installer: Please make sure you provide this manual to the owner of the equipment or to the responsible party who maintains the system.

DISTRIBUTOR AND HOMEOWNER NOTES

1. The Delta Treatment Systems Model E50N has been tested by NSF International and conforms to NSF/ANSI 40 & 245, class 1 effluent requirements. All other E series models are certified based on provisions in the standard for certification of a series of plants of the same model varying only in rated treatment capacity and materials of construction.
2. State and/or local regulations govern the installation and use of individual Aerobic Wastewater Treatment Systems and must be complied with.

Consult your local Sanitarian/Regulatory Agency prior to installation.

HOMEOWNER RECORDS

S/N: _____ DATE OF INSTALLATION: _____

INSTALLED BY: _____

DISTRIBUTOR: _____

This booklet provides operations, installation and warranty information on the **TREATMENT PLANT ONLY**. Other components manuals, such as dosing equipment or drip irrigation, require additional operations and carry separate warranties. Be sure that you have all of the correct manuals for each of the component pieces in your system. Contact your installer or call 1-800-219-9183.

ECOPOD-N® TREATMENT SYSTEMS NOTICE

Post in a Service/Utility Area

ECOPOD-N® TREATMENT SYSTEMS NOTICE

This home is served by an Individual Wastewater Treatment System. This system will serve you well only if it is properly maintained. Your system is comprised of:

Your system is located:

Please do not build on, fill over, allow heavy traffic or allow water to stand over this area. Avoid using strong chemicals, sanitizers, cleaning fluids, etc., which will kill helpful bacteria in the system. You should also avoid flushing grease, food scraps, cigarette butts, sanitary napkins, and other inorganic waste down the drain.

You should have your system serviced (pumped out) every 3 to 5 years, depending on usage. Your service technician can advise you if you need more frequent or additional service.

To have your system serviced, or for additional information, contact Delta Treatment Systems at (800) 219-9183.

All of the details regarding system operation can be found in the homeowner's manual on pages 24-26 of this Installation, Operation and Maintenance Manual. If you did not receive a copy, call (800) 219-9183 and we will send you one at no charge.

Keep a Record of Service Below:

DATE	SERVICE PERFORMED	SERVICE TECHNICIAN

INTRODUCTION

THE DELTA AEROBIC WASTEWATER TREATMENT SYSTEM AND HOW IT WORKS

The ECOPOD-N Fixed Film Wastewater Treatment System you have purchased produces high quality water suitable for various dispersal methods. It is used to enhance your on-site wastewater dispersal system. You can be proud that by purchasing your ECOPOD-N system, with a minimum amount of maintenance, you can directly contribute to a cleaner, safer environment.

All wastewater treatment systems of this type work by using bacteria that nature provides. By pumping air into the system, aerobic bacteria grow and thrive in large numbers. This population of bacteria speeds up the process of breaking down domestic wastewater, making it safer to release into the environment. This entire process takes place within the walls of your specially designed ECOPOD-N Treatment System. The result of this process is a clear, odorless discharge.

By following a few simple steps that you will find in this manual, your ECOPOD-N Fixed Film Wastewater Treatment System will provide you with years of service and the knowledge that you are doing your part to protect public health and our groundwater, lakes, rivers, and streams.

The ECOPOD-N Fixed Film Wastewater Treatment System may be only one of several components required by your health department to provide a complete on-site system.

PROCESS DESCRIPTION

The ECOPOD-N Fixed Film Wastewater Treatment System is a device that houses an engineered plastic media specifically designed to treat domestic wastewater. There are no moving mechanical parts or filters in the chamber or tank that houses the ECOPOD-N.

Wastewater first enters a pretreatment/settling tank similar to a conventional septic tank. In this tank, debris and settleable solids settle to the bottom and are decomposed by anaerobic bacteria. The clarified wastewater then enters the ECOPOD-N, which is submerged in a separate chamber or tank, where it is introduced into an oxygen rich environment. An external air compressor is connected to the ECOPOD-N and provides the necessary air to the system. In this oxygen rich environment, a colony of bacteria, called the biomass, develops and is capable of digesting (breaking down) biodegradable waste. This is a continuous process as the biomass is supplied with incoming wastewater and oxygen.

In this system, conditions are favorable only to attached growth bacteria. This means that the most common disadvantages of other types of systems are eliminated. No rising sludge, floating sludge or washouts can occur.

In addition to cBOD and TSS reduction, ammonia nitrogen is one of the contaminants found in wastewater. Nitrification of the ammonia and denitrification of nitrates occur within the ECOPOD-N system. A 50%+ removal rate of total nitrogen is common without any type of recirculation or cycling of the blower.

HOMEOWNER CARE AND OPERATION INSTRUCTIONS

The ECOPOD-N Fixed Film Wastewater Treatment System has been designed and built to provide long term, reliable and efficient service. Once the unit has been installed (see installation instructions), the unit will operate with a minimum amount of attention.

Please reference the system's Data Plates that are located on the air pump and the alarm panel in the event that a problem arises or service is required.

The following should be performed as checks for system functioning:

Daily

- Observe the warning device, which comes on when the power to the air pump has been interrupted, when the air supply system has malfunctioned, or there is a high water level in the treatment plant. If the alarm is activated, check for a blown fuse or thrown circuit breaker. Check the air pump to be sure it is operating. Once accustomed to the soft humming sound of a properly operating unit, any unusual noise is an indication of malfunction. If an unusual noise is detected or total failure is observed, call an authorized Delta service provider or dealer/distributor.

Weekly

- Check the treatment plant for offensive odor. If such a condition should develop, call an authorized Delta service provider or dealer/distributor.

Every 6 Months for First Two Years After Installation (Annually thereafter the initial 2 years. Performed by a certified service provider)

- Inspect and make any necessary adjustments to mechanical and electrical components.
- Inspect the air filter on the air pump. Rinse with warm water if necessary. (See installation instructions.) Do not use oil or other solvents.
- Inspect effluent quality's color, turbidity and check for odor.
- Take a sample from the reactor tank to check the sludge level described in the "Solids Removal" section.
- The homeowner must be notified in writing if any improper operation is observed and cannot be corrected at the time of service.

Ongoing Maintenance and Care

The following should not be used or disposed of into the system:

- Greases, fats, oils, pesticides, herbicides, or any other toxins.
- Garbage disposal should be used sparingly. Dispose of food waste, grease, etc., in the trash. Food waste represents additional loading on the Fixed Film Wastewater Treatment System and could increase pump-out frequency.

INTRODUCTION

Do not discard the following into the system:

- Paints, household chemicals, automobile fluids, mop water, etc.
- Nonbiodegradable items such as cleaning wipes, cigarette butts, disposable diapers, feminine hygiene products, condoms, coffee grounds, rags, paper towels, bandages, latex, plastic or metallic objects.
- Strong disinfectants or bleaches. Laundry products such as Lysol, Pine-Sol, Tidy Bowl, or discharge from water softeners.
- Septic systems additives – they do more harm than good.
- Excessive water from other sources as this can result in hydraulic overload.
- Home brewery waste, strong medicines, antibiotics and antibacterial soaps should be avoided.

Recommended detergents should contain low-sudsing, low phosphates and biodegradable ingredients. Fabric softener dryer sheets are recommended.

Recommended cleaning products should be biodegradable and nontoxic such as Ivory & Sunlight dish washing liquids, Cascade & Sunlight powdered dishwasher detergents, Comet & Biz powdered cleaners, and baking soda.

SYSTEMS REQUIRING PUMPOUTS DUE TO THE ABOVE VIOLATIONS ARE NOT COVERED BY THE WARRANTY.

The ECOPOD-N Fixed Film Wastewater Treatment System is designed to handle domestic wastewater; nothing else should go into it. For anything other than domestic wastewater, contact Delta Treatment Systems.

SAFETY WARNINGS

The proper operation of this or any other home sewage system depends upon proper organic loading and the life of the microorganisms inside the system. Delta is not responsible for the in-field operation of a system, other than the mechanical and structural workings of the plant itself. Delta cannot control the amount of harsh chemicals or other harmful substances that may be discharged into the system by the occupants of a household; we can only provide a comprehensive owner's manual that outlines substances that should be kept out of the system.

Hydraulic overloading (flows in excess of design flow) may cause the sewage treatment system not to perform to the fullest capabilities.

Ants have been shown to be destructive to the air pump. Regular care should be taken to prevent infestation of ants near the system. Damage or destruction by ants is not covered under manufacturer's warranty.

Your state or local health department may require other pieces of equipment to function separately or in conjunction with equipment manufactured by Delta Treatment Systems. Delta is not responsible for the Mechanical or electrical safety of equipment it does not

manufacture or supply with its fixed film wastewater treatment system. Care should be used in evaluating the electrical or mechanical safety of equipment manufactured by others. This may include but is not limited to electrical control panels or air pumps. If electrical service has not been installed for checking air distribution system during installation, and if an extension cord is used to test the air pump, never leave the extension cord plugged in. Remove it after testing is completed.

DUE TO A POSSIBLE FIRE HAZARD, DO NOT PLUG INTO SERVICE EQUIPMENT ON POWER POLE AND DO NOT USE EXTENSION CORDS. ALL ELECTRICAL WORK PERFORMED BY THE INSTALLER OR OTHERS MUST BE IN ACCORDANCE WITH THE NATIONAL ELECTRICAL CODE AND LOCAL CODES.

SOLIDS REMOVAL

The ECOPOD-N Fixed Film Wastewater Treatment System is designed to provide years of trouble-free operation.

Determination of the need for solids removal can be done with a sludge judge sample. If the sludge judge indicates more than 12 inches of sludge in the bottom of the reactor tank, the treatment plant should be pumped out. Call your local authorized sewage disposal service to have the tank contents pumped out and disposed of properly.

Pumping Method

- The air pump should be in the off position.
- Remove all of the solids from both the reactor tank and primary tank.
- After the pump out process is complete, fill the tank with fresh water to normal operating level.
- Refer to the "Installation Procedure" to get the treatment plant back into operation.
- Should indication of improper operation be observed at any time, contact your local authorized Delta dealer/distributor.

NOTE: THE COST ASSOCIATED WITH PUMPING THE TREATMENT SYSTEM IS NOT COVERED UNDER WARRANTY AND IS NOT INCLUDED IN THE SERVICE POLICY.

SEASONAL USE GUIDELINES OF ECOPOD-N FIXED FILM WASTEWATER TREATMENT SYSTEM

These guidelines are for conditions as outlined below and apply for systems that are not in use for periods of time indicated. Site conditions not covered by the following must be forwarded to Delta for recommended guidelines to meet the particular site conditions.

1. System not in use for more than one month and less than three months. Electrical power is left on and there are no frost conditions.
 - Leave air pump on and system running.

INTRODUCTION

2. System not in use more than three months. Electrical power is turned off and there are no frost conditions.
 - Remove all materials and liquid from tank.
 - Refill with clean water.
 - Turn off air pump.
3. System not in use more than three months. Electrical power is on and there are no frost conditions.
 - Leave air pump on and system running; OR
 - Remove all material and liquid from tank.
 - Refill with clean water.
4. System not in use. Electrical power is turned off and there are frost conditions.
 - Remove all material and liquid from tank.
 - Turn off air pump.
 - If high groundwater is present, fill with clean water.
 - If no groundwater is present, leave tank empty.

UNDER NO CIRCUMSTANCES SHOULD THE AIR PUMP BE TURNED OFF FOR MORE THAN A FEW DAYS WITHOUT REMOVING TANK CONTENTS

SAMPLING REQUIREMENTS

An ECOPOD-N Fixed Film Wastewater Treatment System properly operated and maintained should provide the following effluent quality of:

Biochemical oxygen demand 5 day average (BOD₅) of less than 30 mg/l (or ppm)

Suspended solids of less than 30 mg/l (or ppm)

Volatile

Suspended solids of less than 30 mg/l (or ppm)

pH of 6.0 to 9.0

Dissolved oxygen 1.5 to 3.0 mg/l (or ppm)

Taking Effluent Sample

Samples must be taken in the effluent discharge line or an effluent pump tank or after the disinfection device. We recommend allowing the effluent to flow through the discharge line for a minimum of 4 minutes before taking the sample. This will allow any solids to be flushed out that might have accumulated in the discharge pipe. Please see Figure 1 for reference.

SAMPLES SHOULD BE TAKEN BY A LOCAL CERTIFIED TESTING LABORATORY. THE

FOLLOWING RECOMMENDED GUIDELINES MAY BE USED IF LOCAL PROCEDURES ARE NOT AVAILABLE.

Grab Samples: If analysis is begun within two hours of collection, cooling is unnecessary. If analysis is not started within two hours of sample collection, keep sample at or below 4°C from the time of collection. Begin analysis within six hours of collection; when this is not possible because the sampling site is distant from the laboratory, store at or below 4°C and report length and temperature of storage to the lab. In no case, start analysis more than 24 hours after grab sample collection. When samples are to be used for regulatory purposes, make every effort to deliver samples for analysis within six hours of collection.

1. Biochemical Oxygen Demand (BOD)

Samples for BOD analysis may degrade significantly during storage between collection and analysis, resulting in low BOD values. Minimize reduction of BOD by analyzing the sample promptly or by cooling it to near freezing temperature during storage. However, even at low temperature, keep the holding time to a minimum. Warm the chilled samples to 20°C before analysis; some storage time can be used to accomplish this conveniently.

2. Total Suspended Solids (TSS)

Use resistant-glass or plastic bottles, provided that the material in suspension does not adhere to container walls. Begin analysis as soon as possible because of the impracticality of preserving the sample. Refrigerate sample at 4°C to minimize microbiological decomposition of solids.

3. Ammonia Nitrogen

Most reliable results are obtained from fresh samples. Destroy residual chlorine immediately after sample collection to prevent its reaction with ammonia. If prompt analysis is impossible, preserve samples with 0.8 mL concentration H₂SO₄/L sample and store at 4°C. The pH of the acid-preserved samples should be between 1.5 and 2. Some wastewater may require more concentration H₂SO₄ to achieve this pH. If acid preservation is used, neutralize samples with NaOH or KOH immediately before making the determination.

SAMPLE

Figure 1

SAMPLE PROCEDURES:

(If Applicable)

1. PRIOR TO TAKING SAMPLE HAVE ECOPOD PLANT DISCHARGE EFFLUENT FOR UP TO 4 MINUTES BY FLUSHING TOILETS AND/OR USE GARDEN HOSE TO FLUSH OUT SAMPLE PORT.
2. INSERT SAMPLE COLLECTING BOTTLE TO COLLECT ONLY EFFLUENT THAT IS CASCADING OVER THE CASCADING EDGE.
3. HANDLE, STORE, AND TRANSPORT SAMPLES AS SPECIFIED BY POLICIES AND PROCEDURES PROVIDED BY THE TESTING LABORATORIES.

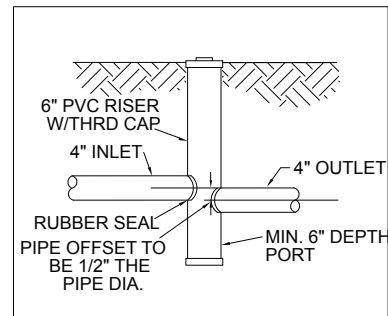
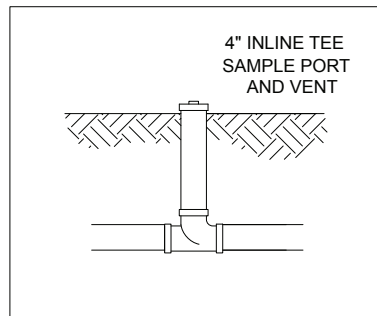
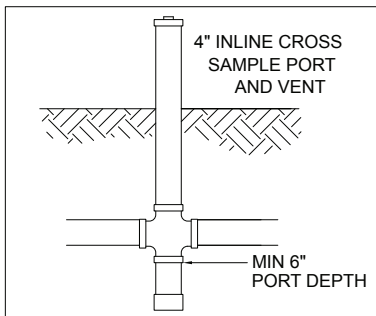
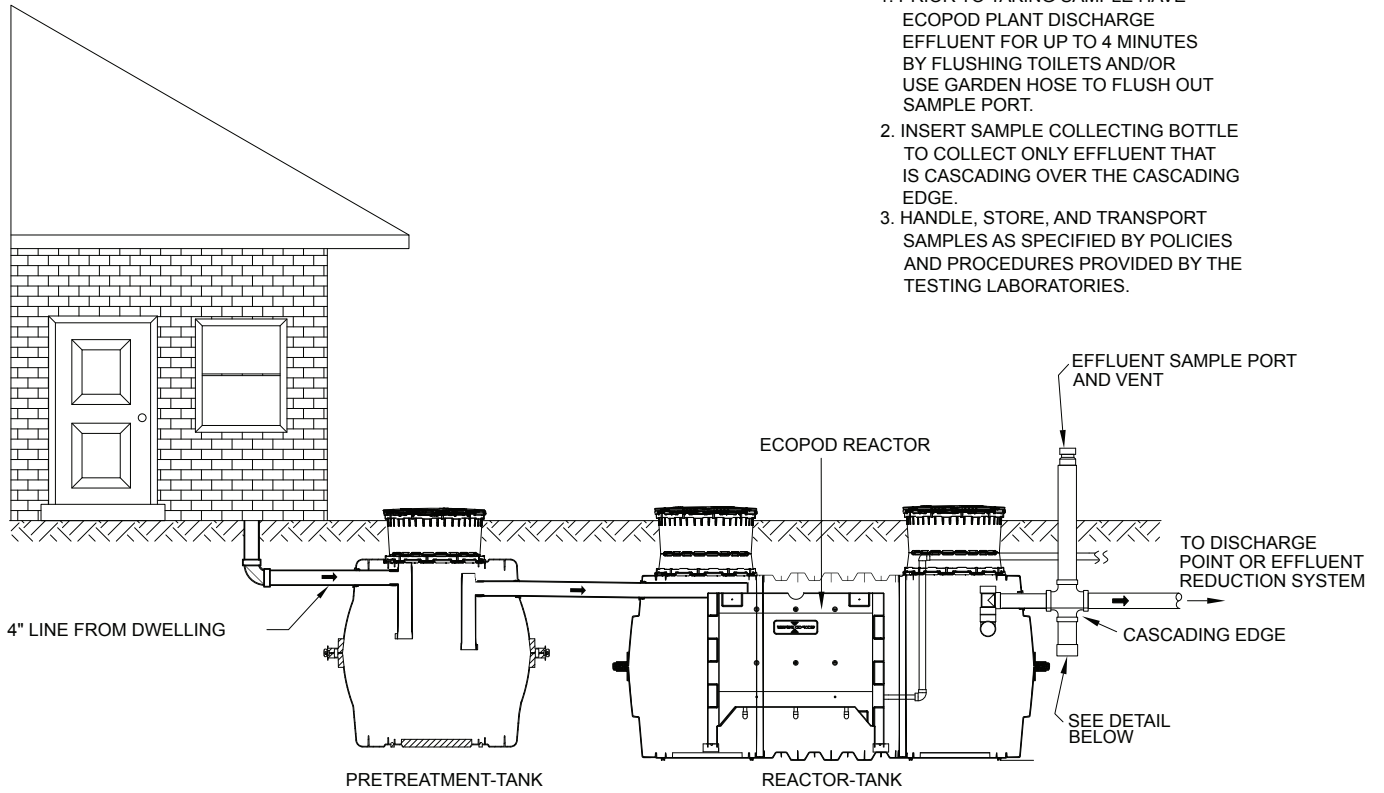

INSTALLATION INSTRUCTIONS

ONLY FOR USE BY CERTIFIED, LICENSED INSTALLERS

1. Tank Delivery and Handling

Care must be taken offloading and unpacking tank and components. Care must be taken not to damage tank and components with forklift or any other offloading device. Check for damaged tank and components that may have occurred in transportation and notify factory or distributor within 24 hours of delivery.

2. Set and Backfill Tanks

An ECOPOD-N Treatment System will require a pretreatment tank. Depending on the supplier it may be integrated into a single tank or require setting a separate tank. Proper fall between tanks is required and is specified by local regulatory code requirements. Excavate and set tank as recommended by the tank manufacturer. Prior to backfill, install tank access risers as needed. It is very important to follow all backfill and compaction procedures required by the tank manufacturer.

Figure 2

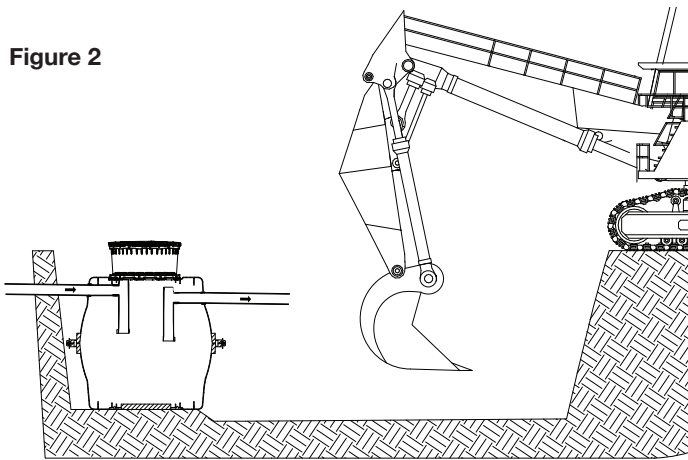
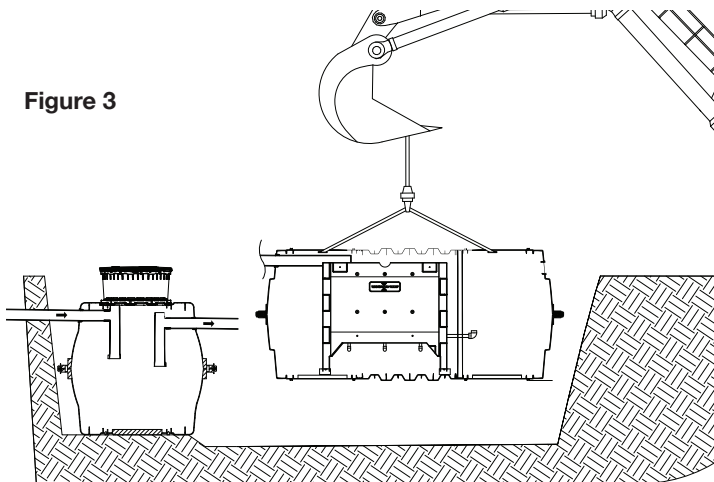

Figure 3



Note: It is recommended that any excavation be roped off with caution tape for jobsite safety.

3. Plumb Tank Inlets and Outlets

Plumb and solvent weld all inlet and outlet piping on the pretreatment tank (if applicable) and reactor tank. The pretreatment tank plumbing requirements are specified by local regulatory code. The reactor tank inlet piping should extend more than 12 inches into the tank and terminate above of the ECOPOD-N reactor box. The reactor tank outlet tee assembly should be solvent welded to the outlet pipe and must extend six to twelve inches into the outlet side of the tank. The inlet piping should be sloped downward toward the ECOPOD and the outlet piping should sloped downward and away from the tank.

4. Fill Reactor Tank with Clean Water

Begin filling the reactor tank with clean water while the air distribution and control panel assembly are completed. Continue filling the tank until water level reaches the outlet tee. It will take several hours using residential water service.

Figure 4

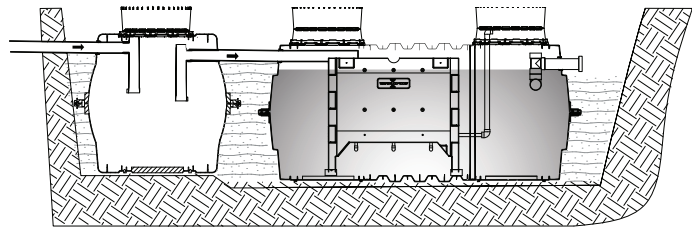

5. Plumb Air Distribution System

Plumb in the air distribution system. Prime and solvent weld all connections. Bring 2-inch Schedule 40 PVC line out of the tank and through the riser sidewall. Extend PVC air distribution piping from the riser to where the compressor will be located. A minimum of 12" ground cover is recommended over the air distribution piping. Connect compressor to the PVC air distribution piping:



- A. If using the regenerative blower (FPZ model SCL06) attach the 1x6 galvanized nipple to the 1-inch galvanized elbow, then attach the 2-inch Schedule 40 PVC reducer to the 1-inch galvanized nipple. Next connect the PVC line to the PVC reducer using PVC solvent.

INSTALLATION INSTRUCTIONS



B. If using the linear blower (Thomas model LW250) attach the 1-inch galvanized male adapter to the blower using the supplied hose and clamps. Next attach the 2-inch Schedule 40 PVC reducer to the male adapter, then connect the PVC line to the reducer using PVC solvent.

7. Air Compressor Placement

Do not install the air pump(s) in a low-lying area where water may accumulate. The air pump should be installed near the control panel and within 100 ft. of the reactor tank. The air pump can be installed outdoors or in a clean, well ventilated area, such as a tool room, garage, etc.

8. Mounting Control Panel

Mount the control panel in a location such that the alarm can be heard and be readily observed. The control panel must be connected to a 20-amp maximum electrical source equipped with a ground fault interrupter (GFI) circuit breaker. Install a power disconnect switch to the panel that is operable and available to a maintenance provider. The control panel must be grounded. Connect the source ground wire to the ground location in the panel. All electrical work shall be done according to NEC and local code requirements.

- A. Attach control panel to a suitable mounting surface. Use appropriate screws for all four mounting holes on the back of the enclosure.
- B. The control panel contains a fuse or circuit breaker for the air pump. An electrical malfunction in the air pump, or wiring to the air pump, will cause the fuse or circuit breaker to blow. The control panel also contains a pressure switch and visual and audible alarms. Loss of air pressure caused by air pump system malfunction, or a high-water level in the treatment tank, will cause the alarm to sound and light to illuminate.
- C. Control panel is rated for outdoor service. However, do not place it where it can be immersed in rising water or where runoff water such as from a roof will pour onto it. Do not mount it where it is subject to wetting from sprinklers, hoses, etc.
- D. Connect conduit. After the control panel is properly mounted, connect conduit and install wiring as shown on drawings bound herein (Schematics).
- E. Connect the pressure air tubing to the 1/8" barb-fitting in the air piping system. The air tubing should be protected by conduit as shown on the drawing.

9. System Startup

Turn power on. Once the tank water level reaches the outlet tee, turn power on to control panel. Air pump should start.

Figure 5

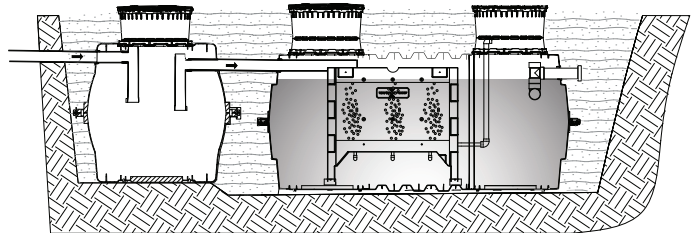

- A. Set the high-level pressure switch. To set the high-level pressure switch that detects high water level in the unit bring the tank to operating water level with compressor turned on. Using properly sized screwdriver turn high level alarm adjustment screw clockwise until alarm occurs. Then turn the screw counterclockwise until alarm stops.

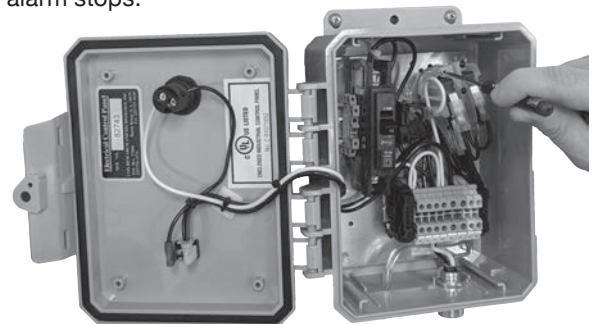

- B. Check air piping joints for leakage using a soapy water solution. Repair if necessary and then carefully backfill air distribution piping and tanks.
- C. Finish grade the site. Divert surface water away from the system and install or plant ground cover to prevent erosion.
- D. Tank is ready to receive incoming sewage. No special start-up procedures are required. The process is naturally occurring and does not require any special additives.
- E. Replace and secure all tank access lids. Close up the enclosure door on control panel and lock if necessary.
- F. Spend time with your customer whenever possible. Review operation instructions. Be sure that the customer has a manual to keep. This saves valuable time avoiding return visits.
- G. Retain these instructions for future reference.

WARNING: CONTROL PANEL CONTAINS HIGH VOLTAGE AND MUST BE INSTALLED AND SERVICED ONLY BY QUALIFIED PERSONNEL

TROUBLE SHOOTING GUIDE

Air Supply Malfunction

1. Check to be sure air distribution is working properly. This will be evident in the reactor as the liquid will be forcefully agitated. A septic (rotten egg) odor could mean that the system is not getting enough air. If the air system is not working, partially working or working very little (slight bubbles), check the following:
 - A. Check to be sure the air pump is working.
 - Check timer if one is used.
 - Bypass timer temporarily and connect directly to source.
 - Check the electrical source.
 - If electrical source is okay, check service guide on pump unit for troubleshooting information.
 - Wash air filter on pump.
 - Consult manufacturer for servicing information.
 - B. Check to be sure tank is not severely out of level. Air follows a path of least resistance. The pressure differences can be enough to restrict air flow.
 - C. Check for broken or cracked air lines both outside and inside the tank.
 - D. Ants will destroy an air pump. Check to see if there is an ant nest around the air pump.
 - E. Air pump should be protected from rising water.
 - F. Always check to see if inlet and outlet lines are correctly installed.

Internal Assembly Malfunction

1. Primary treated wastewater from the primary tank should not enter directly into the quiescent zone because of improperly installed or loose seals or gaskets where pipe goes through the tank wall. Check the size of holes to be sure that there is no clearance for matter to pass through the wall around the piping.
2. Check to be sure all internal piping and connections are tight.

Design Overload

1. The system could be hydraulically overloaded (there is too much water going through the system for the size of the system).
2. The system could be biologically overloaded (there is too much waste for the size of the system).

Improper Installation or Settling

1. You should follow the manufacturer's installation procedures very carefully.

2. Where settling is common, approximately 2" of a well graded bedding material should be placed and tamped in the bottom of the hole.
3. Proper installation is the first step in preventing callbacks for service problems.
4. Whenever possible, it is important to spend time with the homeowner. Be sure they have an operations book. A few minutes invested in the beginning will avoid service calls later.

No Harsh Chemicals Should Be Put into the System

1. Water in the reactor tank should be relatively clear in both the reactor and quiescent zones. Blue or gray/blue water indicates heavy use of detergents or other chemicals. If water appears sudsy there is too much detergent being used.
2. Water in the quiescent zone should be clear. Water is discharged into the discharge tee at a minimum of 6–8 inches below water surface. You MAY NOT be able to see clear water by looking into the tank. Samples must be taken at the sample port.
3. Oils and grease should be kept to a minimum. Grease tends to form in white balls.

Troubleshooting Electrical System

1. Air pump does not run:
 - A. Check main service for power.
 - B. Check and/or replace fuse with same rating as in control panel.
2. Alarm does not occur when air pump is off:
 - A. Malfunctioning pressure switch – replace.
 - B. Malfunctioning light or buzzer – replace.
3. Alarm occurs continuously even when air pump is running:
 - A. Air leak in main air system or air tubing to pressure switch – repair leak or replace air line.
 - B. Malfunctioning pressure switch – replace.
 - C. High water level in tank – inspect for cause.
 - D. Short in float switch wire or float switches – repair or replace.

NOTE: ALL REPLACEMENT PARTS ARE AVAILABLE FROM YOUR LOCAL DISTRIBUTOR.

CAUTION: ELECTRICAL SHOCK OR HAZARD MAY OCCUR IF UNIT IS NOT SERVICED PROPERLY. THE MANUFACTURER RECOMMENDS THAT A LICENSED ELECTRICIAN BE CALLED WHEN ELECTRICAL PROBLEMS OCCUR.

TROUBLE SHOOTING GUIDE

GENERAL COMMENTS

1. Only factory approved equipment can be used for replacement on individual treatment systems.
2. If the decision is made to pump out a system, be sure to contact a licensed waste hauler.
3. If a chronic problem develops and all items have been checked, consult with the factory.
4. Taking pictures of systems when troubleshooting will help document activity in the field.
5. Keep good records.

SPECIFICATIONS

ECOPOD-N Unit Specifications

Treatment Plant	Treatment Capacity (GPD)	Minimum Primary Tank or Chamber Total Volume (Gal)	Reactor Tank or Chamber Volume (Gal)	Reactor Tank or Chamber Dilution Volume (Gal)	Media Size	Air Requirements
E50N	500	500	710	590	2'x2'x4'	12 CFM
E60N	600	600	916	736	2'x2'x6'	14.4 CFM
E75N	750	750	1090	910	2'x2'x6'	18 CFM
E100N	1000	1000	1405	1165	2'x2'x8'	24 CFM
E150N	1500	1500	2100	1740	2'x2'x12'	36 CFM

MATERIALS OF CONSTRUCTION

Suffix FF	Reactor Tank	Fiberglass
	Cover	Fiberglass
	Media Container	Polyethylene
Suffix CA	Reactor Tank	Concrete
	Cover	Concrete
	Media Container	Polyethylene
Suffix IM	Reactor Tank	Polypropylene
	Cover	Polypropylene
	Media Container	Polyethylene

These are standard production units. Other configurations are available upon request.

ECOPOD-N Electrical Requirements

Model	Compressor	Motor Full Load Amps	Measured Operating Watts	Electrical Requirements
E50N	Delta Model 06	3.5	185	115 volt – single phase
E60N	Delta Model 06	4.7	280	115 volt – single phase
E75N	Delta Model 06	4.7	280	115 volt – single phase
E100N	Delta Model K03	7.1	475	115 volt – single phase
E150N	Delta Model K03	7.1	475	115 volt – single phase

ECOPOD-N Reactor Tank Dimensions

Treatment Plant	A	B	C	D
E50N	47"	44"	54.7"	127"
E60N	47"	44"	54.7"	127"
E75N	47"	44"	54.7"	127"
E100N	47"	44"	55"	176"
E150N	47"	44"	55"	176"

SPECIFICATIONS

ECOPOD-N Dimensions (IM-1060 Series Tank)

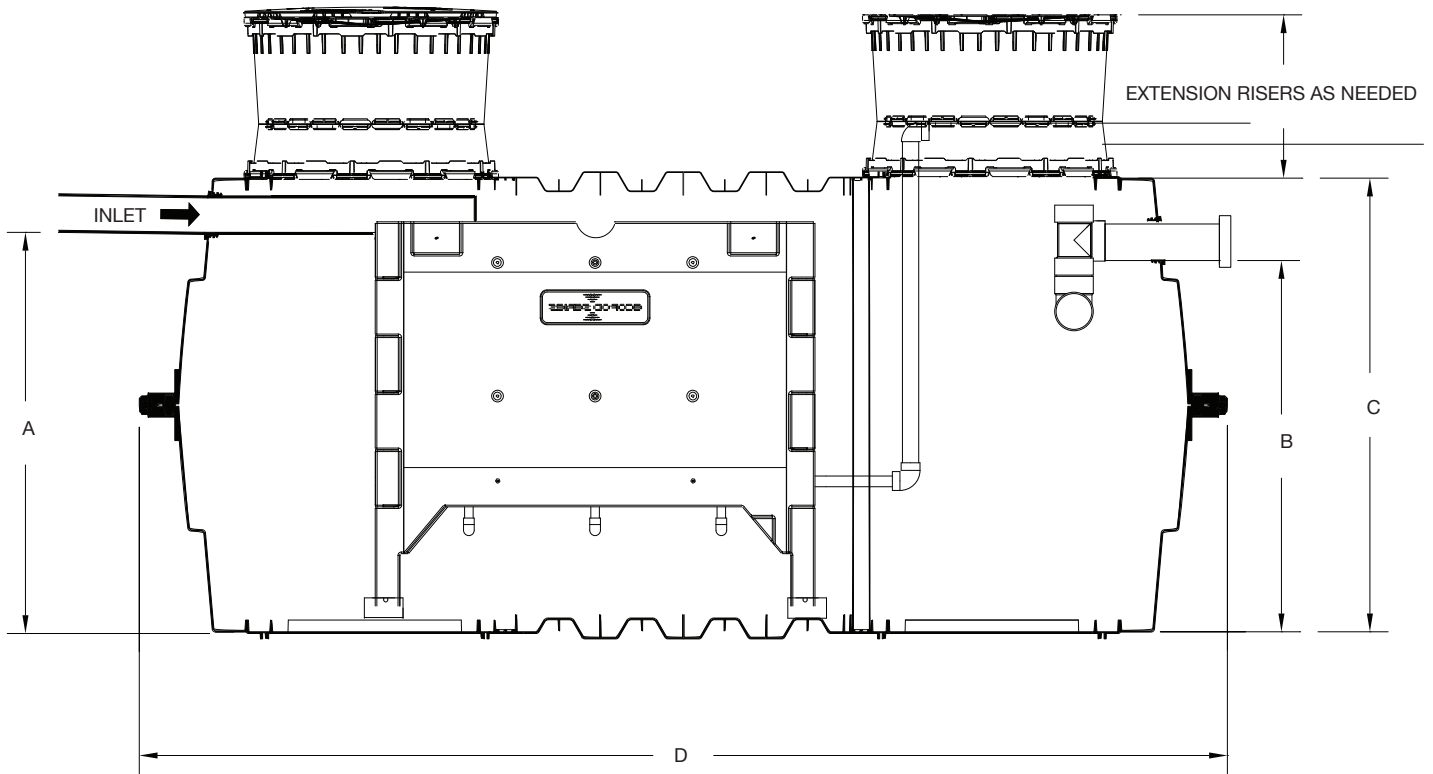

Concrete Dimensions

Note: Concrete dimensions for reactor tank or chamber only. A 2-compartment concrete tank may also be used, the first compartment being used for pre-treatment.

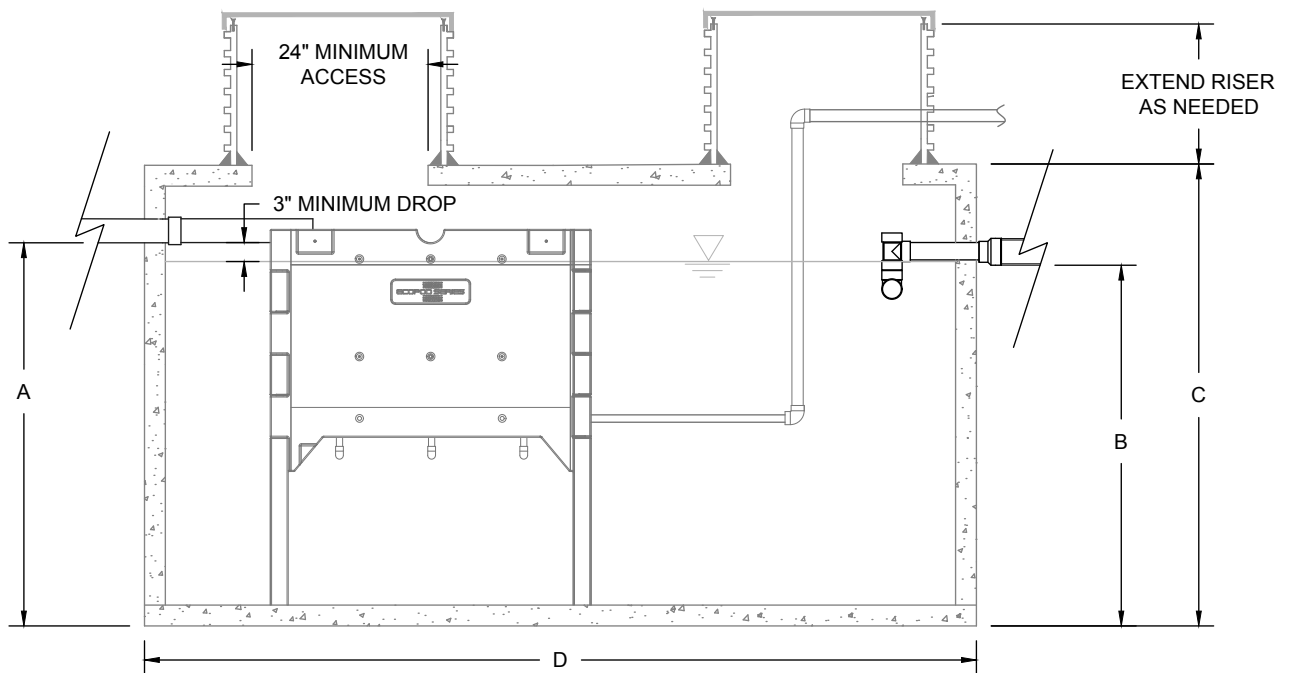

CONTROL PANEL CONNECTION

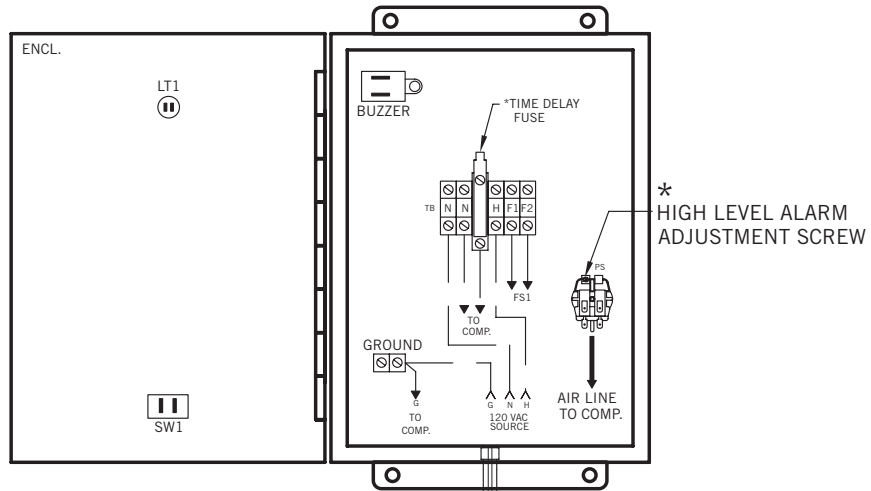

FRONT VIEW
DOOR OPEN
CP22

* SETTING HIGH LEVEL PRESSURE SWITCH

- BRING PLANT TO OPERATING LEVEL WITH COMPRESSOR TURNED ON
- USING PROPERLY SIZED SCREWDRIVER, TURN HIGH LEVEL ALARM ADJUSTMENT
- SCREW CLOCKWISE UNTIL ALARM OCCURS, THEN TURN THE SCREW COUNTERCLOCKWISE UNTIL ALARM STOPS.

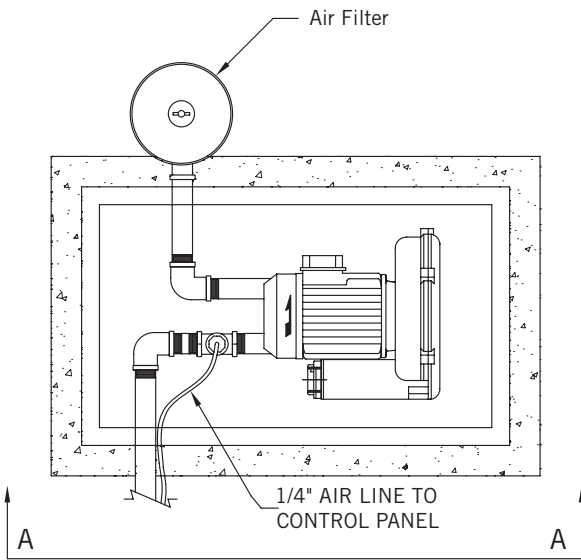

PRESSURE SWITCH TUBING

BLOWER ENCLOSURE

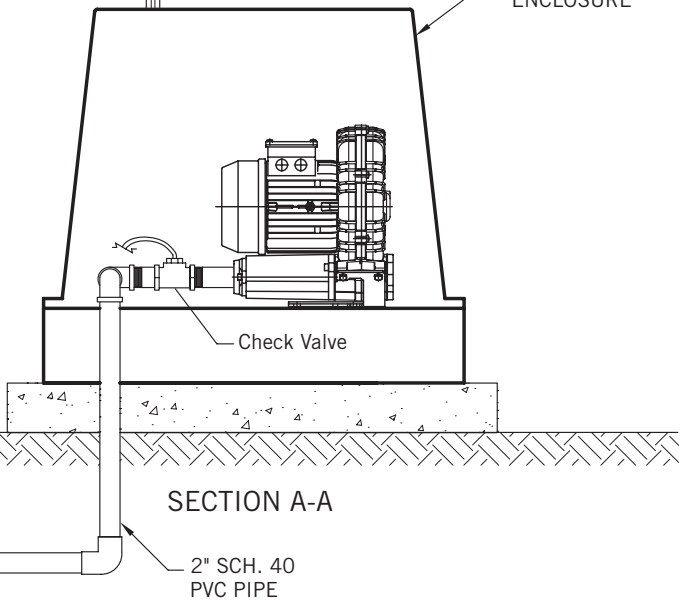

CP2210 SCHEMATIC

CP2210/ECO/FG/UL CONTROL PANEL
 MAX FULL LOAD AMPS - 8
 VOLTS - 120
 PHASE/HZ - 1/60
 TYPE 4X ENCLOSURE

EXTERNAL DISCONNECT AND
 BRANCH CIRCUIT CONNECTION
 BY OTHERS (20 AMP MAXIMUM)

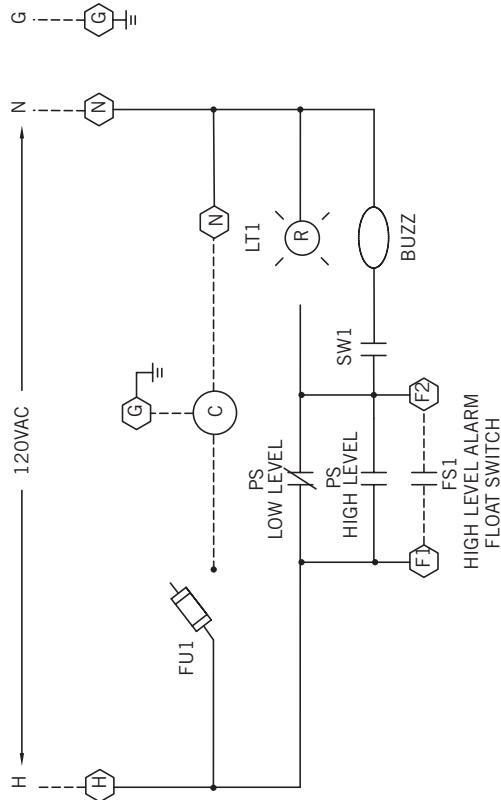

SCHEMATIC DIAGRAM CP2210/ECO/FG/UL

SHORT CIRCUIT RATING: 5KA

FUSE SELECTION CHART

MOTOR FULL LOAD CURRENT	TYPICAL TIME DELAY FUSE SIZE REQUIRED	CRT PART NO.
1-4 AMPS	5 AMPS	AE845-4180
4-8 AMPS	10 AMPS	AE845-4184
8-12 AMPS	15 AMPS	AE845-4187
12-16 AMPS	20 AMPS	AE845-4188

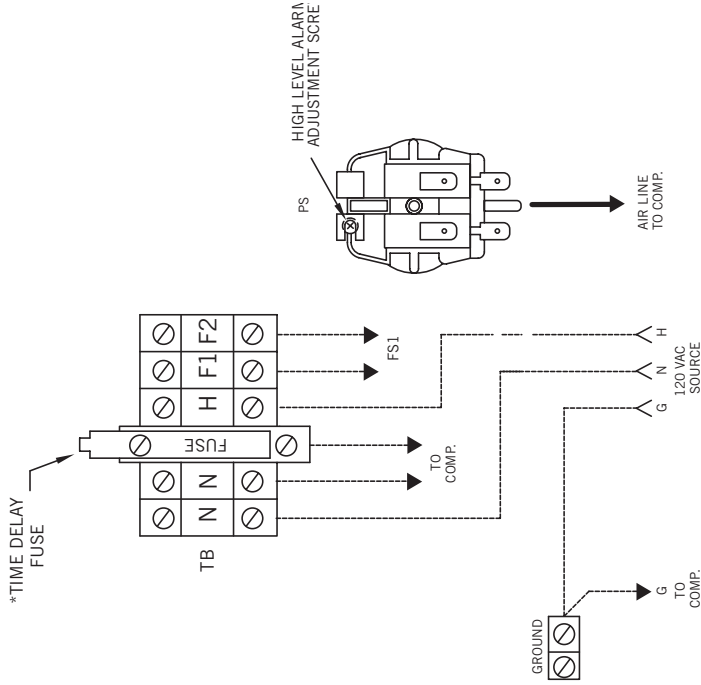

EXTERNAL WIRING

- ### SETTING HIGH LEVEL PRESSURE SWITCH
- BRING PLANT TO OPERATING WATER LEVEL WITH COMPRESSOR TURNED ON.
 - USING PROPERLY SIZED SCREWDRIVER, TURN HIGH LEVEL ALARM ADJUSTMENT.
 - SCREW CLOCKWISE UNTIL ALARM OCCURS. THEN TURN THE SCREW COUNTERCLOCKWISE UNTIL ALARM STOPS.

CP2220/ECO/FG/UL CONTROL PANEL
 MAX FULL LOAD AMPS - 8
 VOLTS - 120
 PHASE/HZ - 1/60
 TYPE 4X ENCLOSURE

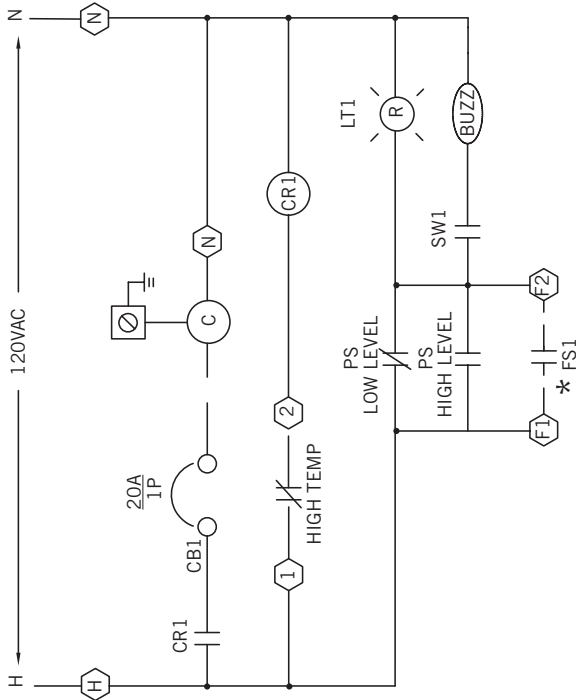

SCHEMATIC DIAGRAM
 CP2220/ECO/FG/UL

SHORT CIRCUIT RATING: 5KA

- * FS1 - H.L. FLOAT SWITCH IN TREATMENT PLANT
- A SEPARATE DISCONNECT IS REQUIRED.

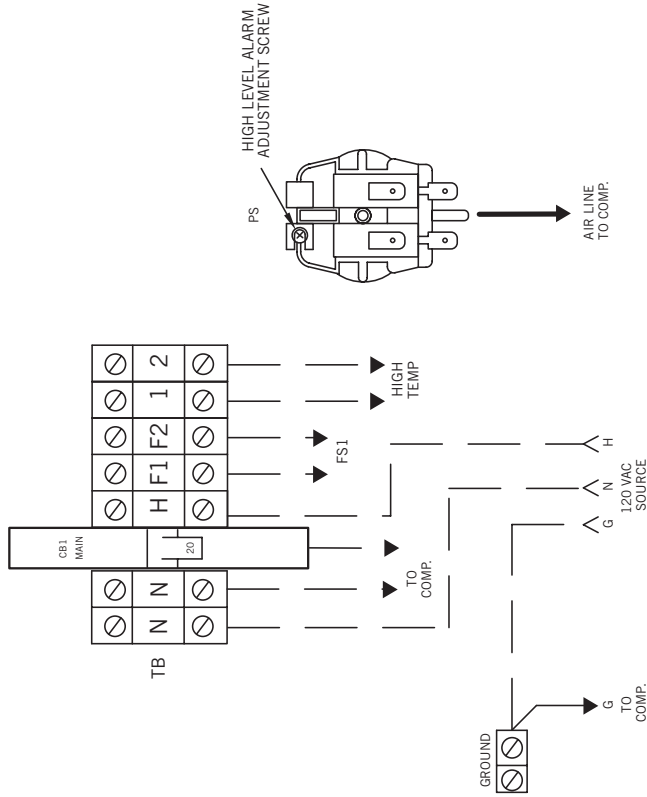

EXTERNAL WIRING

SETTING HIGH LEVEL PRESSURE SWITCH

- BRING PLANT TO OPERATING WATER LEVEL WITH COMPRESSOR TURNED ON.
- USING PROPERLY SIZED SCREWDRIVER, TURN HIGH LEVEL ALARM ADJUSTMENT.
- SCREW CLOCKWISE UNTIL ALARM OCCURS. THEN TURN THE SCREW COUNTERCLOCKWISE UNTIL ALARM STOPS.

CP220 SCHEMATIC

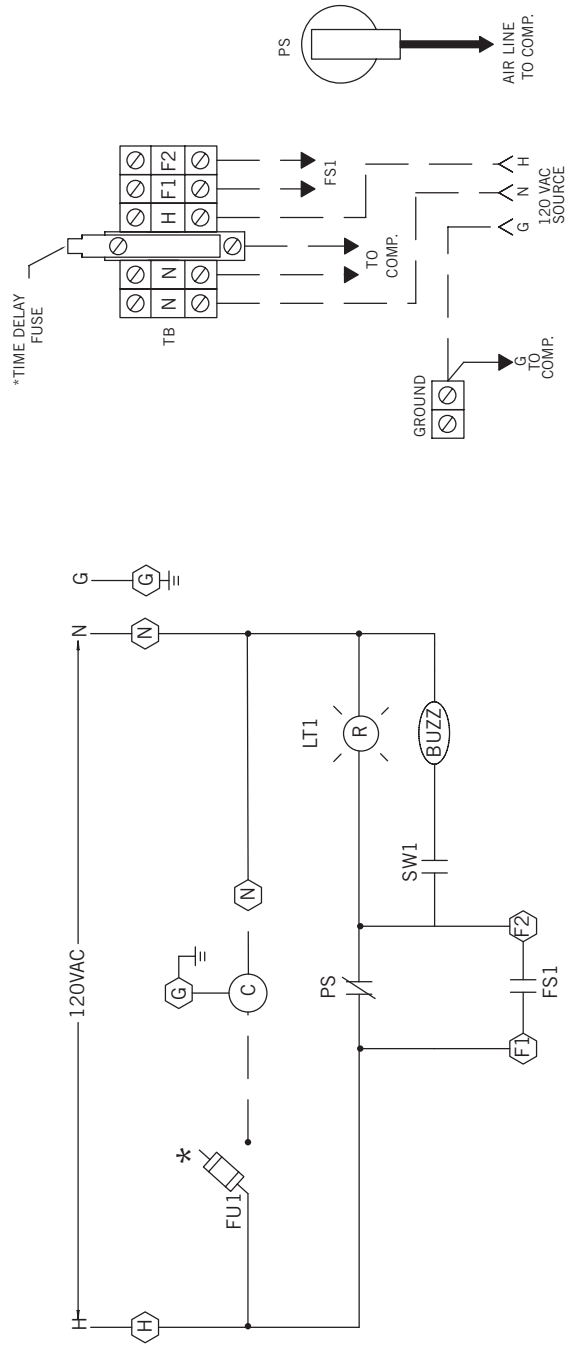

SCHEMATIC DIAGRAM
CP20 SERIES

* FUSE SIZE VARIES WITH COMPRESSOR SIZE
PER NATIONAL ELECTRICAL CODE



F.P.Z. GmbH
 Kilianstraße 142
 90425 NÜRNBERG
 Tel. 0911.36.76.68.00
 Fax 0911.36.76.68.01
 E-mail deutschland@fpz.com

LATERAL CHANNEL BLOWERS - EXHAUSTERS

SCL 06 MOR

SN 1750-0

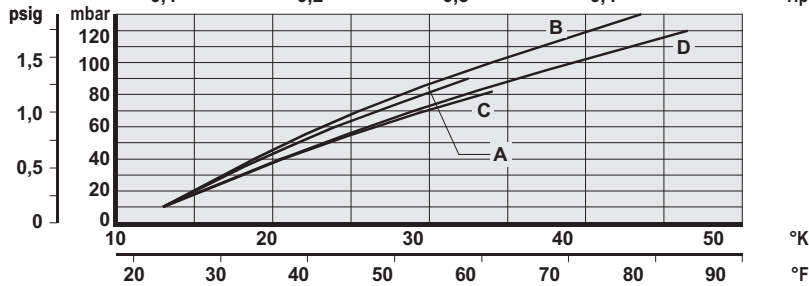
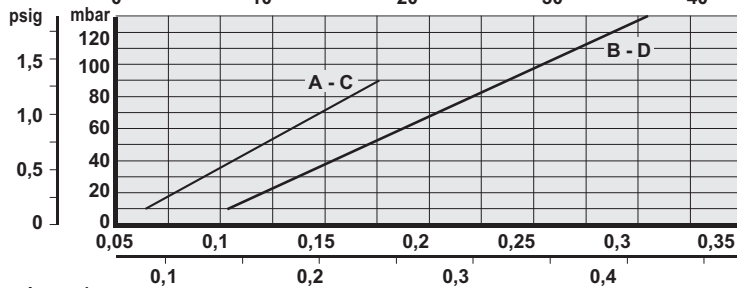
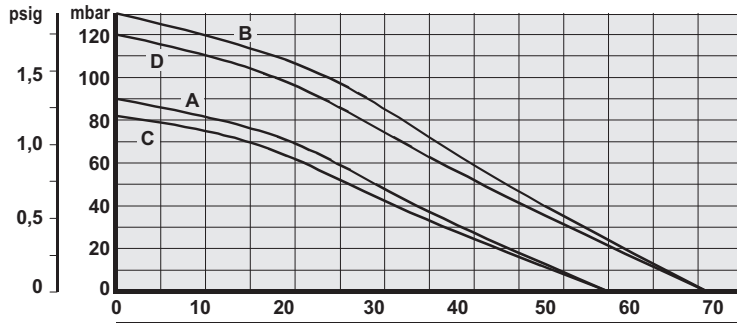

P ⁽¹⁾ kW	Δp ⁽²⁾ mbar psig		Q ⁽³⁾ m³/h cfm	
------------------------	--------------------------------	--	------------------------------	--

COMPRESSOR

A 50 Hz - 2900 rpm				
0.2	90	1.30	0	0

B 60 Hz - 3500 rpm				
0.23	80	1.16	32	19
0.4	130	1.88	0	0

EXHAUSTER

C 50 Hz - 2900 rpm				
0.2	82	1.18	0	0

D 60 Hz - 3500 rpm				
0.23	80	1.16	28	16
0.4	120	1.74	0	0

kW	H	m
50 Hz - 60 Hz		Kg
0.2 - 0.23	235	6.5
0.4	235	7.1

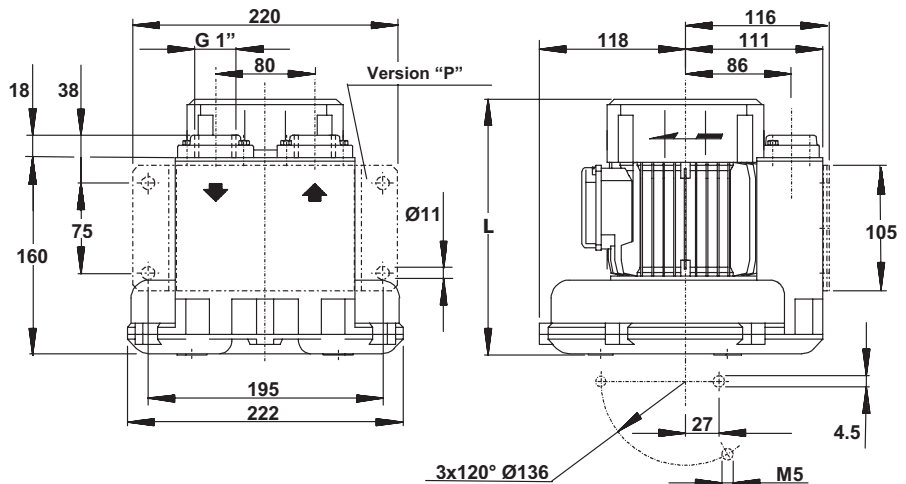

MAXIMUM NOISE LEVEL	
	Lp dB(A)
50 Hz - 2900 rpm	58
60 Hz - 3500 rpm	59

To allow the perfect performing of the machine, it has to be equipped with the INLET FILTER and the SECURITY VALVE AT LEAST; other accessories available on request.

- (1) Installed power.
- (2) Maximum differential pressure referred to installed motor.
- (3) Inlet flow at max differential pressure per installed motor.

The characteristics data given, refer to the handling of gas with inlet temperature of 15°C, normal density of 1,23 kg/m³ and absolute pressure of 1013 mbar in suction in case of performing as compressor, in discharge in case of performing as exhauster. Dimensions in mm. Noise level measured at 1 m distance with in/outlets piped. Tolerance on given values ±10% - unbinding and can be changed without prior notice.



FPZ, Inc
 150 N. Progress Drive
 Saukville, WI 53080 - U.S.A.
 Tel. (262) 268-0180
 Fax (262) 268-0415
 E-mail usa@fpz.com

REGENERATIVE BLOWERS - PRESSURE
SCL K03 / K04 / K05 / K06
MS SERIES - MOR RANGE
 SN 1874-8 1/2

TECHNICAL CHARACTERISTICS

- Aluminum alloy construction
- Smooth operation
- High efficiency impeller
- Maintenance free
- Mountable in any position
- Recognized TEFC - cURus motor

OPTIONS

- Special voltages (IEC 38)
- Surface treatments

ACCESSORIES

- Inlet and/or inline filters
- Additional inlet/outlet silencers
- Safety valves
- Flow converting device
- Optional connectors

Dimensions in inches.
 Dimension for reference only.

Possible alternative positions,
 please refer to drw SI 1839

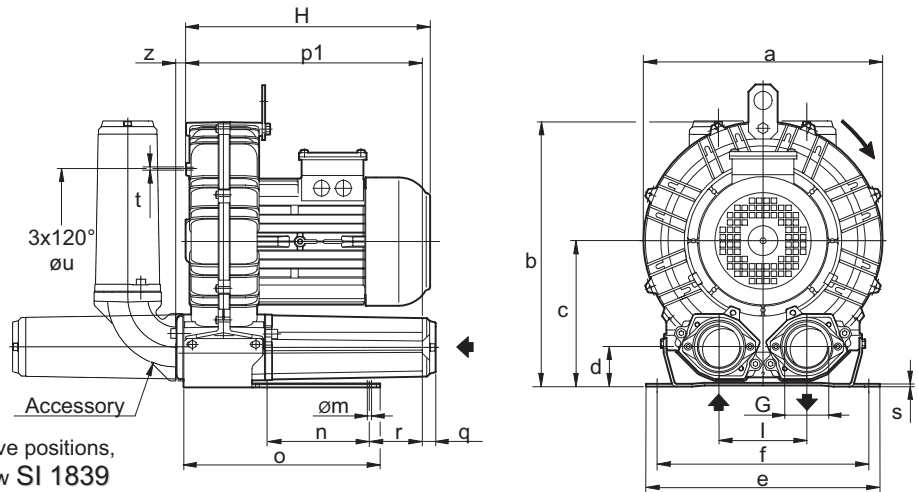

Model	a	b	c	d	e	f	G	l	m	n	o	p1	q	r	s	t	u	z
K03-MS	9.49	10.55	5.79	1.69	9.06	8.07	1 1/4 NPT	3.39	0.39	3.27	5.59	8.07	0.71	2.95	0.16	M6	5.51	0.47
K04-MS	11.22	12.40	6.77	1.93	10.04	8.86	1 1/2 NPT	4.02	0.47	3.74	6.73	8.74	0.71	2.76	0.16	M6	6.89	0.71
K05-MS	12.87	14.37	7.87	2.13	12.60	10.24	2" NPT	4.72	0.59	4.53	10.43	12.60	0.71	3.86	0.16	M8	7.87	0.75
K06-MS	14.80	15.47	8.07	2.13	12.80	11.42	2" NPT	4.92	0.59	5.51	10.71	13.15	0.71	3.35	0.16	M8	9.45	0.75

Model	Maximum flow Scfm		Installed power Hp		Maximum differential pressure Δp (In WG)		Noise level Lp dB (A) ⁽¹⁾		Overall dimensions H Inches	Weight Lbs
	60 Hz 3500 rpm	50 Hz 2900 rpm	60 Hz 3500 rpm	50 Hz 2900 rpm	60 Hz 3500 rpm	50 Hz 2900 rpm	60 Hz 3500 rpm	50 Hz 2900 rpm		
	K03-MS	52	43	3/4	3/4	64	60	62.0	60.0	10.43
K04-MS	98	81	1 1/2	1 1/2	58	80	64.8	62.8	11.65	36.40
			2	2	85	100	65.0	63.0	13.78	43.00
			3	-	120	-	65.2	-	13.78	49.60
K05-MS	156	129	2	2	52	70	70.5	68.5	13.20	51.80
			3	3	90	110	70.8	68.8	13.20	58.40
			4	4	128	120	71.1	69.1	14.40	67.20
K06-MS	216	179	3	3	50	65	73.0	71.0	13.54	68.70
			4	4	75	95	73.3	71.3	14.17	71.65
			5 1/2	5 1/2	110	140	73.6	71.6	14.17	77.60
			6 1/5 ⁽²⁾	-	132	-	73.9	-	14.45	77.60

(1) Noise measured at 1 m distance with inlet and outlet ports piped, in accordance to ISO 3744.
 (2) No cURus motor

- For proper use, the blower should be equipped with inlet filter and safety valve; other accessories available on request.
- Ambient temperature from +5° to +104°F.
- Specifications subject to change without notice.



REGENERATIVE BLOWERS - PRESSURE
SCL K03 / K04 / K05 / K06
MS SERIES - MOR RANGE
 SN 1874-8 2/2

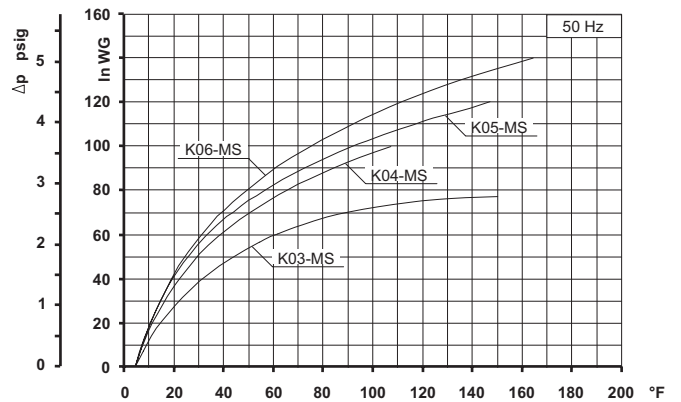
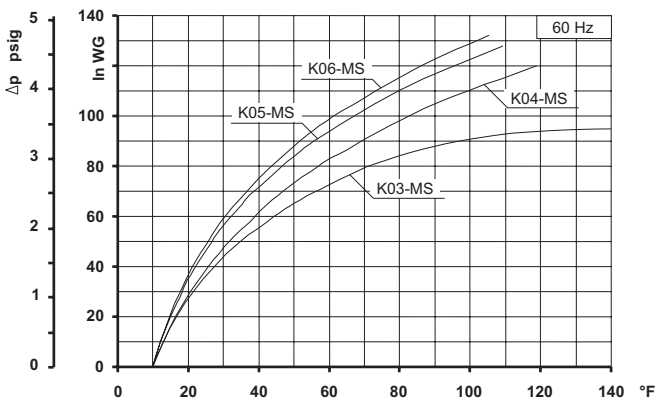
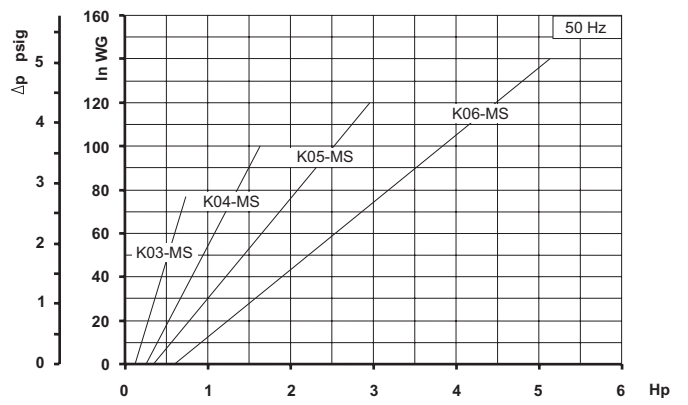
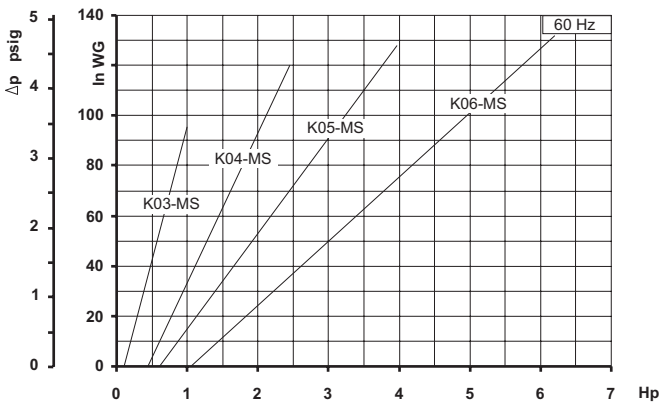
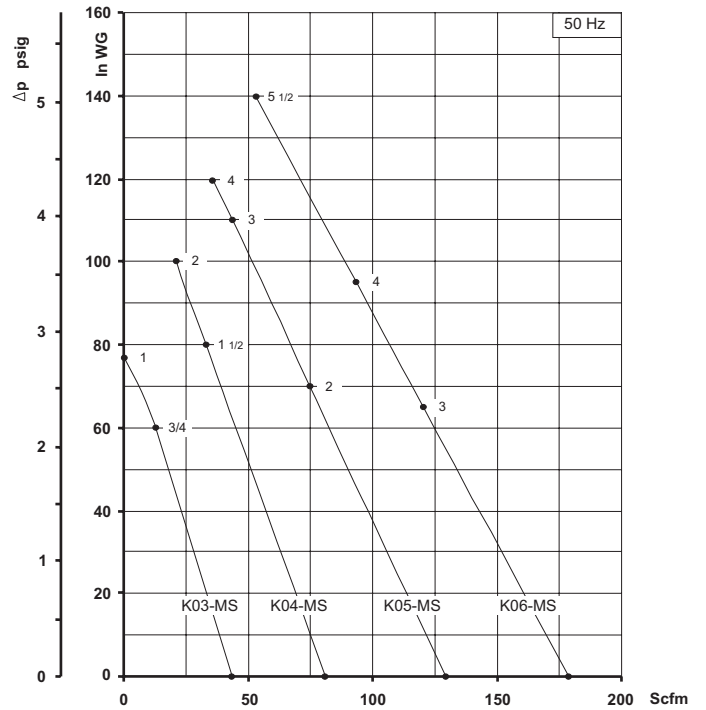
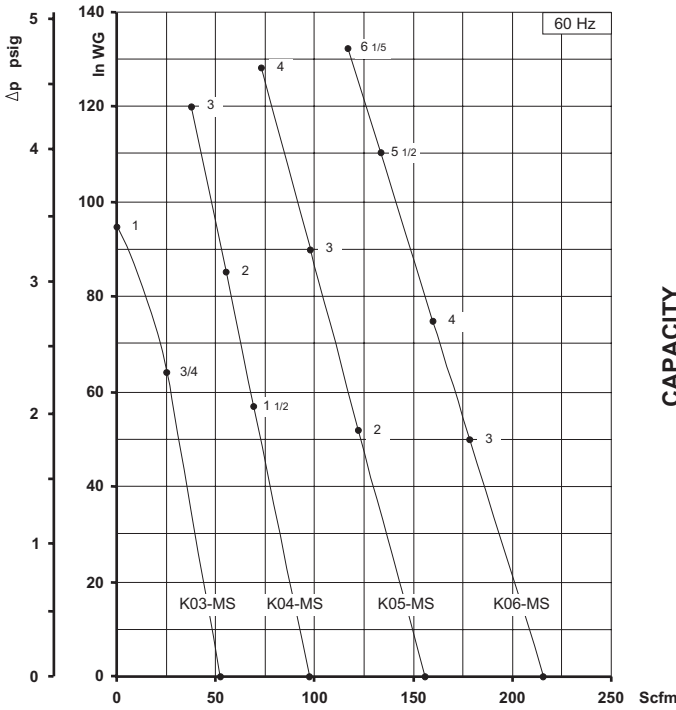

Curves refer to air at 68°F temperature and 29.92 In Hg atmospheric pressure (abs) measured at inlet port.
 Values for flow, power consumption and temperature rise: +/-10% tolerance.
 Data subject to change without notice.

ECOPD-N SERIES DATA PLATES

4"



9125 COMAR DRIVE WALKER, LA 70785
1-800-219-9183

THE ECOPOD N SERIES™

Model E

NSF/ANSI STDS 40 & 245
 GPD CLASS 1

Serial No.



2"

4"



9125 COMAR DRIVE WALKER, LA 70785
1-800-219-9183

ALARM MALFUNCTION ELECTRICAL PANEL

THE ECOPOD N SERIES™

Model E

NSF/ANSI STDS 40 & 245
 GPD CLASS 1

Serial No.



3"

SERVICE POLICY

DELTA TREATMENT SYSTEMS INDIVIDUAL MECHANICAL WASTEWATER TREATMENT SYSTEM SERVICE POLICY

INITIAL POLICY:

A two-year initial service policy shall be furnished to the user by the manufacturer or the distributor through the dealer. This policy may be included in the price of the system, provided the state in which the system is being installed has adapted NSF Policies as part of their state rules

1. **An inspection/service call every six months**, which includes inspection, adjustment, and servicing of the mechanical and electrical component parts as necessary to ensure proper function.
2. An effluent quality inspection every six months consisting of a visual check for color, turbidity, scum overflow, and an examination for odors.
3. If any improper operation is observed that cannot be corrected at that time, the user shall be notified immediately in writing of the conditions and the estimated date of correction. **THIS POLICY DOES NOT INCLUDE PUMPING SLUDGE FROM UNIT IF DEEMED NECESSARY.**

CONTINUING SERVICE POLICY:

An annually renewable service policy affording the same coverage as the Initial Service Policy is available. Consult your dealer for pricing information. The annually renewable service policy should provide the same service checks as the initial NSF service policy and should be performed twice per year.

PARTS:

Replacement parts or components may be obtained from your local distributor or contact Delta Treatment Systems for information.

COMPLAINTS:

In order for Delta Treatment Systems to properly address complaints, we require that you put in writing the date and nature of the complaint as detailed as possible. This **MUST** include the serial number of your system.

Send to: Delta Treatment Systems
9125 Comar Drive
Walker, LA 70785

Delta Treatment Systems

Homeowner's Manual: Onsite Wastewater Treatment System

A Guide to the Proper Care and Maintenance of Your Onsite Wastewater Treatment System

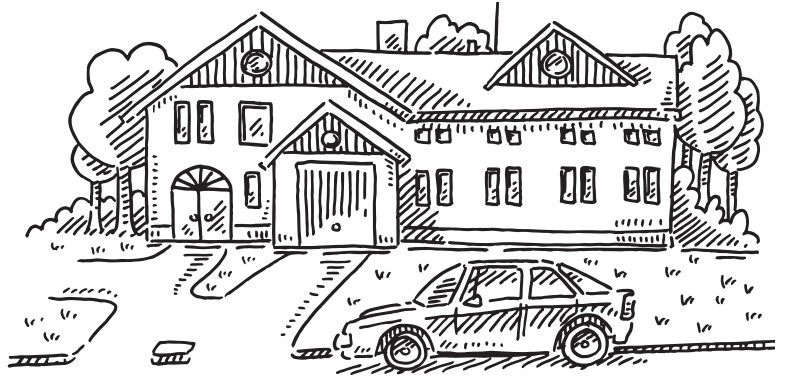

How to Take Care of Your Wastewater Treatment System

Congratulations, your home is now serviced by a meticulously engineered wastewater treatment system. Your new Delta wastewater treatment system is designed for the collection and treatment of your household wastewater.

When properly maintained, onsite wastewater treatment systems efficiently treat household wastewater and recycle local groundwater. Delta wastewater treatment systems use little energy and can often outperform municipal sewage treatment plants. The treated wastewater, or effluent, is often returned to the soil where it will receive a final level of treatment before it reenters and recharges the groundwater. With an onsite wastewater treatment system there's no degrading of our nation's rivers and oceans, which is often the case with municipal sewer system outflows.

Your Delta wastewater treatment system is like any other engineered system, like your heat pump or

your car. Engineered systems will last longer and offer optimal performance if maintained regularly by a qualified service provider. In the case of your Delta wastewater treatment system, the service provider will likely be the person who installed the system as they're the most familiar with the ins and outs of the system and where all of the components are located on your property.

Aside from regularly scheduled maintenance of the system, it's also important to be cautious of what you put into the system. The following pages outline some of the do's and don'ts to keep in mind to ensure the longevity of your Delta wastewater treatment system.

By following a maintenance schedule and our best practice recommendations in the do's and don'ts section, your Delta wastewater treatment system should function for decades. You'll also save water, energy, and pumpout costs, too!



Don't flush dangerous or damaging substances into your system.

Wastewater Treatment System Inside the Home



DO's



Collect any cooking grease or leftover oils in a container and dispose of them in your trash can. Compost food scraps or dispose of them into the trash can. Food byproducts can accelerate the need for pumping of your tank and increase overall maintenance cost.

Keep lint out of your wastewater treatment system by cleaning the lint filters on your washing machine and dryer before every load. Installing a supplemental lint filter on your washing machine would be a good precautionary measure.

Try to use substitutes for common hazardous waste that can be found in many cleaners. Replace the following with products that are less harmful to the environment.

- **Ammonia-Based Cleaners for Baking Soda/**

- Vinegar:** For surfaces, sprinkle baking soda on a damp sponge. For windows, use a solution of 2 tbs (30 mL) white vinegar to 1qt (1 L) water and pour the mixture into a spray bottle.

- **Carpet/Upholstery Cleaners for Cornstarch/**

- Baking Soda:** Sprinkle dry cornstarch or baking soda on the surface and then vacuum.

- **Disinfectants for Borax:** Use ¼ cup (50 g) of Borax in a half-gallon (2 L) of water and store in a spray bottle. This solution will also work as a deodorizer.

- **Drain Decloggers:** Use a plunger or snake to remove and clean the drain trap.

- **Scouring Cleaners & Powders for Baking Soda/**

- BonAmi® cleanser:** Sprinkle baking soda on a damp sponge or add 4 tbs (50g) baking soda to 1 qt (1 L) warm water. Or use BonAmi® cleanser; it's less expensive and is less likely to scratch the surface.

- **Furniture/Floor Polishes for Oil Soap/Lemon**

- Juice:** Use oil soap and warm water, and dry with a soft cloth. To polish, use 1 part lemon juice and 2 parts oil (any kind) or use natural products with lemon oil or beeswax in mineral oil.

- **Laundry Detergents:** Choose a liquid detergent without chlorine or phosphates. Avoid using powdered detergents.

- **Metal Cleaners for Toothpaste/Lemon:** To polish

silver gently rub with toothpaste and soft wet cloth. To clean and polish brass and copper, scrub with half of a lemon dipped in salt. To clean stainless steel, use a scouring pad and soapy water.

- **Oven Cleaners for Baking Soda/BonAmi®**

- cleanser:** Sprinkle the surface with baking soda or Bon Ami® then scrub with an unused toilet brush.

Practice water conservation with these tips. Using excessive amounts of water can cause hydraulic overload of the system. On average, 50 gallons (200 liters) per person per day is typical. Below are some water conservation tips to consider to ensure you're not overloading the system.

- Take shorter showers or baths with a partially filled tub. Be cautious about excessive use of large soaking tubs.

- Don't let water run unnecessarily while brushing teeth or washing hands, food, dishes, etc.

- Don't use the dishwasher or washing machine unless you have a full load. And, when possible avoid doing several loads in one day.

- Install water-saving devices on faucets and showerheads.

- When you need to replace an old toilet, replace it with a low-flush model.

Wastewater Treatment System Inside the Home



DON'T'S



Don't flush dangerous or damaging substances into your system.

- Pharmaceuticals
- Excessive Amounts of Bath or Body Oils
- Water Softener Backwash
- Flammable or Toxic Products
- Household Cleaners
- Chlorine Bleach, Chlorides, and Pool/Spa Products
- Pesticides, Herbicides, Agricultural Chemicals, or Fertilizers
- Eggshells, Cantaloupe Seeds, Gum, Coffee Grounds, or Tea Bags
- Chewing Tobacco or Cigarette Butts
- Condoms, Dental Floss, Sanitary Napkins or Tampons, Diapers
- Paper Towels, Newspapers, Candy Wrappers
- Large Amounts of Hair
- Baby, Medicated, or Cleaning Wipes (even those that claim to be "flushable" on the packaging)

Don't plumb water softener discharge brine into your wastewater system (softened water is ok, just not the brine that is produced during the regeneration cycle). Route the brine around your wastewater system so it discharges directly into the soil.

Don't use special additives that are marketed to enhance the performance of your system. Additives can cause damage in other areas of the collection system by disrupting the natural microorganisms that are currently growing within the system.

Don't leave interior faucets on to protect water lines during cold weather. A single running faucet can easily increase your daily flow up to 3,000 gallons per day and hydraulically overload your system. Properly insulate or heat your faucets and plumbing in preparation for winter months.

Don't ignore leaky plumbing fixtures. A leaky toilet can waste up to 2,000 gallons (7,500 liters) of water per single day, 10-20 times more water than an average household's daily use. Leaky plumbing fixtures increases your water bill, wastes natural resources and causes unnecessary overload on your system.

Wastewater Treatment System Do's and Don'ts: Outside the Home

Do's:

- Keep the tank's access lid secure at all times. Never open or attempt to enter the tank. Gasses present within the tank can be fatal. If you find the lid has become loose contact your service provider or Delta Treatment Systems.
- Plan landscaping and permanent outdoor structures before installation of the system.

Don'ts:

- Never drive over any buried components of the system. If your system is in an area that could potentially be subject to any vehicular traffic place a barricade like a row of shrubs around it.

- Don't dump waste from your RV. This will not only cause an increase to the frequency of septage pumping but, when dumped directly into the pumping vault, RV waste clogs or fouls equipment causing unnecessary maintenance and repair costs. Additionally, some RV waste may contain chemicals that are toxic or may have a negative impact to the biological digestion occurring within the tank.
- Don't connect rain gutters or storm drains to the system or allow any surface water to enter it.
- Don't discharge hot tub water into your system.
- Don't dig without knowing the location of your wastewater system components.

WARRANTY

DELTA TREATMENT SYSTEMS, LLC (“DELTA”) DELTA TWO (2) YEAR ECOPOD® SERIES MATERIALS AND WORKMANSHIP LIMITED WARRANTY

- (a) This limited warranty is extended to the end user of a Delta ECOPOD® Series Advanced Wastewater Treatment Product (the “ECOPOD® Product”). An ECOPOD® Product manufactured by Delta, when installed and operated in accordance with Delta’s installation instructions and local regulation by a licensed installer, is warranted to you: (i) against defective materials and workmanship for two (2) years after installation. Delta will, at its option, (i) repair the defective product or (ii) replace the defective materials. This Warranty does not cover any damage caused by flooding, abuse, unauthorized disassembly, improper wiring or overload protection. This Warrant does not cover any of the house wiring, plumbing, drainage or disposal systems.
- (b) In order to exercise your warranty rights, you must notify Delta in writing at its corporate headquarters in Walker, Louisiana within fifteen (15) days of the alleged defect. Delta reserves the right to inspect the item to confirm that it is defective.
- (c) YOUR EXCLUSIVE REMEDY WITH RESPECT TO ANY AND ALL LOSSES OR DAMAGES RESULTING FROM ANY CAUSE WHATSOEVER SHALL BE SPECIFIED IN SUBPARAGRAPH (a) ABOVE. DELTA SHALL IN NO EVENT BE LIABLE FOR ANY CONSEQUENTIAL OR INCIDENTAL DAMAGES OF ANY KIND, HOWEVER OCCASIONED, WHETHER BY NEGLIGENCE OR OTHERWISE. SOME STATES DO NOT ALLOW THE EXCLUSION OR LIMITATION OF INCIDENTAL OR CONSEQUENTIAL DAMAGES, SO THIS LIMITATION OR EXCLUSION MAY NOT APPLY TO YOU. THIS WARRANTY GIVES YOU SPECIFIC LEGAL RIGHTS AND YOU MAY ALSO HAVE OTHER RIGHTS WHICH VARY FROM STATE TO STATE.
- (d) THIS LIMITED WARRANTY IS THE EXCLUSIVE WARRANTY GIVEN BY DELTA AND SUPERSEDES ANY PRIOR, CONTRARY, ADDITIONAL, OR SUBSEQUENT REPRESENTATIONS, WHETHER ORAL OR WRITTEN. DELTA DISCLAIMS AND EXCLUDES TO THE GREATEST EXTENT ALLOWED BY LAW ALL OTHER WARRANTIES, WHETHER EXPRESS OR IMPLIED, OR STATUTORY, INCLUDING ANY WARRANTY OF MERCHANTABILITY, FINESSE FOR A PARTICULAR PURPOSE AND ANY IMPLIED WARRANTIES OTHERWISE ARISING FROM COURSE OF DEALING, COURSE OF PERFORMANCE, OR USAGE OF TRADE. NO PERSON (INCLUDING ANY EMPLOYEE, AGENT, DEALER, OR REPRESENTATIVE) IS AUTHORIZED TO MAKE ANY REPRESENTATION OR WARRANTY CONCERNING THIS PRODUCT, EXCEPT TO REFER YOU TO THIS LIMITED WARRANTY. EXCEPT AS EXPRESSLY SET FORTH HEREIN, THIS WARRANTY IS NOT A WARRANTY OF FUTURE PERFORMANCE, BUT ONLY A WARRANTY TO REPAIR OR REPLACE DEFECTIVE COMPONENTS.
- (e) YOU MAY ASSIGN THIS LIMITED WARRANTY TO A SUBSEQUENT PURCHASER OF YOUR HOME.
- (f) NO REPRESENTATIVE OF DELTA HAS THE AUTHORITY TO CHANGE THIS LIMITED WARRANTY IN ANY MANNER WHATSOEVER, OR TO EXTEND THIS LIMITED WARRANTY BEYOND THE STATED TWO (2) YEAR TERM.
- (g) NO WARRANTY OF ANY KIND IS MADE WITH REGARD TO ANY PRODUCT, COMPONENTS, DEVICES, MEDIA OR TREATMENT UNITS WHICH ARE MANUFACTURED BY OTHERS AND ARE INSTALLED IN CONNECTION WITH THE ECOPOD® PRODUCT. USE OF THESE PRODUCTS ARE AT YOUR OWN RISK.

CONDITIONS AND EXCLUSIONS

There are certain conditions or applications over which Delta has no control. Defects or problems as a result of such conditions or applications are not the responsibility of Delta and are NOT covered under this warranty. They include failure to install the ECOPOD® Product in accordance with instructions or applicable regulatory requirements or guidance and altering the ECOPOD® Product contrary to the installation instructions.



DELTA TREATMENT SYSTEMS, LLC
9125 Comar Drive, Walker, LA 70785
(225) 665-6162 • (800) 219-9183
www.deltatreatment.com
info@deltatreatment.com