

DELTA TREATMENT SYSTEMS

ECOFILTER™ Pump Vault

SYSTEM SPECIFICATIONS

Product Use

Delta Treatment Systems' Ecofilter Pump Vault systems are designed for septic and effluent tank pumping. The Ecofilter can either be used in an advanced wastewater treatment system or in a STEP collection system. The Ecofilter Pump Vault has a unique structural design to ensure long life and performance.

Product Description

Delta Treatment Systems' Ecofilter Pump Vault systems include a molded LDPE housing, polypropylene and PVC filter, schedule 40 PVC discharge kit, schedule 80 PVC support pipes, float level controls, submersible high head effluent pump, and control panel. The filter and float tree are designed to allow removal for cleaning without removal of the pump or housing. The housing is capable of accommodating a simplex or pumping configuration.

Materials of Construction	
Housing	100% Recycled Low Density Polyethylene
Filter	Polypropylene / PVC
Float Tree	Schedule 40 PVC
Support Pipe	Schedule 80 PVC
Float Control	Narrow Angle, Normally Open Mercury Level Control
Discharge Kit	Schedule 40 PVC

Pump Vault Specifications		
Model	DEPV-49-20-1	DEPV-57-20-1
A - Vault Height (in)	49	57
Filter Diameter (in)	9-3/4	9-3/4
B - Filter Height (in)	40-11/16	48-11/16
Filter Screen Opening (in)	0.125 0.0625	0.125 0.0625
Filter Surface Area	1848 in ²	2208 in ²
Filter Open Area	814 in ²	973 in ²
Housing Inlet Height (in)	14	14
Pump Off/On/Alarm Level (from top of vault, in)	14 / 10 / 6.25 Adjustable	22.5 / 17.5 / 12.5 Adjustable

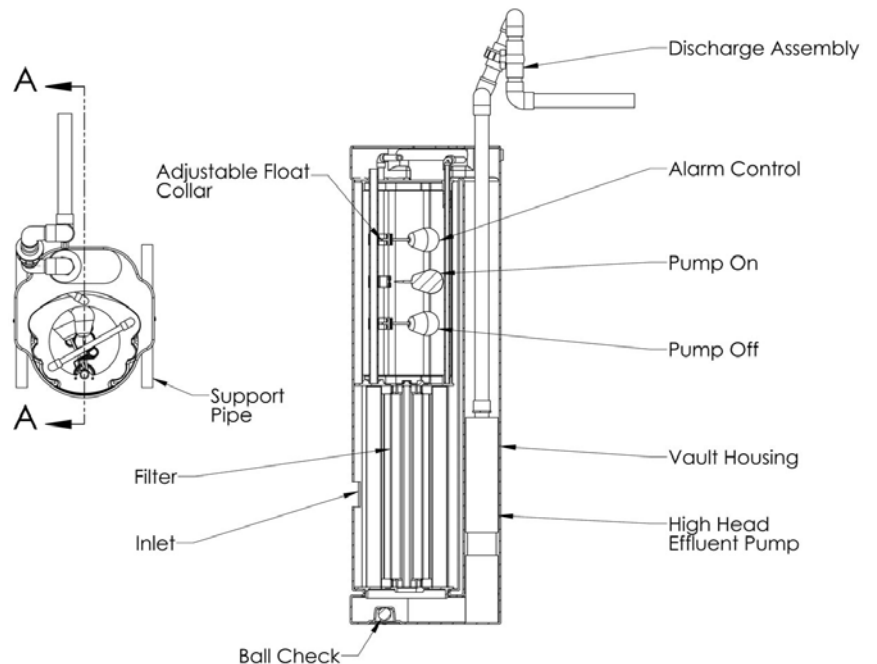
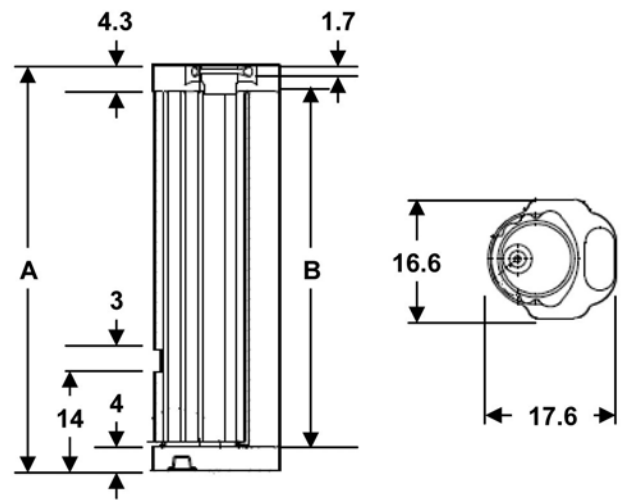

System Specifications

Pump Specifications	
Pump Flow Rate (Gallons per Minute / GPM)	Standard – 20 Optional – 8, 12 20, 30, 50 GPM
RPM	3450
HP	1/2
Voltage	115
Phase	1
Frequency	60 Hz
Full Load Amps	14.5 – 8 to 20 GPM only
Motor Protection	Built-in overload and surge protection
Max Starts per Day	300
Discharge Size	1-1/4"
Cable Length	25'
Cable Type	14-3 Jacketed SJOW-A
Max Liquid Temperature	122°F
Backflow Protection	Built-in check valve

Pump Materials Of Construction	
Pump Housing	300 Series Stainless Steel
Shaft	300 Series Stainless Steel
Impeller	Thermoplastic
Suction Bowl	Chemically Resistant Reinforced Nylon
Discharge Bowl	Corrosion Resistant Reinforced Polycarbonate

Performance Data

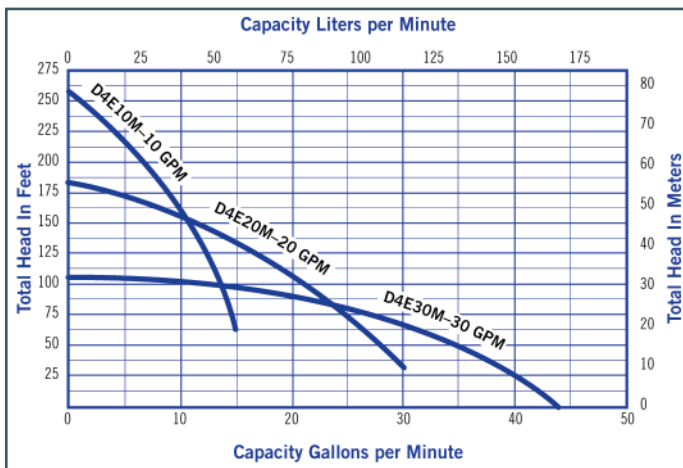

Control Panel Specifications	
Enclosure Dimensions	10"x8"x4"
Overall Dimensions	12"x10"x5.5"
Enclosure Type	UL Type 4X with Molded Mounting Feet
Audible Alarm	Includes Normal – Silence switch
Alarm Light	Flashing Red
Controller Temp Range	-140°C thru 185°C
Humidity Range	95% non-condensing
Voltage to Floats	120 – 230 VAC
Voltage to Pump Relays	120 VAC

Control Panel Features

Standard Features

- Standard control devices
- Pump on/off
- Alarm light and buzzer
- Lockable latch
- HOA switch
- Normal-Silence switch
- Pump and controls circuit breakers
- Motor Magnetic Contactor
- 2 or 3 float operation
- All finger safe components

Available Options

- Elapsed Time Meter
- Cycle Counter
- Run Indication Light
- Power Indication Light
- Programmable Timer
- PLC Smart Panel
- Lighting Arrestor
- Remote Mentoring
- Custom – Call Factory



9125 COMAR DRIVE, WALKER, LA 70785 1 (800) 219-9183 | WWW.DELTATREATMENT.COM

Because we are continuously improving our products and services, Delta reserves the right to change specifications without prior notice.
K4561 04/2018 © 2018 Delta Treatment Systems, LLC All Rights Reserved.